

BROMPTON

ELECTRIC



Brompton Electric
C & P Line

Owner's manual

EN15194:2017

CPSC 16 CFR 1512

COMPONENT NAMES

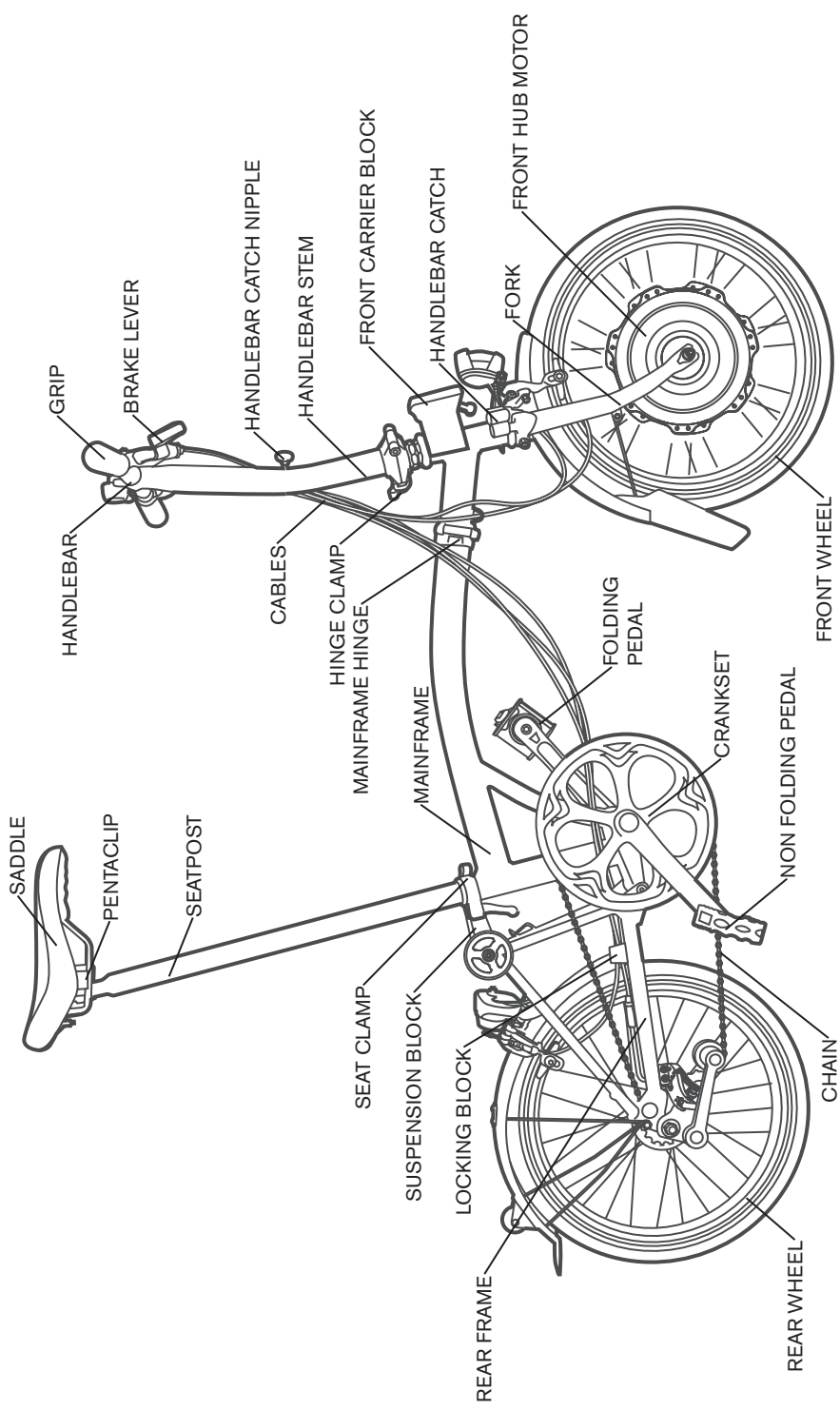

CONTENTS

INTRODUCTION	4
SAFETY	6
WARNING	7
DECLARATION OF CONFORMITY	8
ITEMS SUPPLIED WITH THE BIKE	9
FITTING/REMOVING THE BATTERY & BAG	10
THE ELECTRIC ASSIST SYSTEM	11
USING THE LIGHTING	16
MAINTENANCE INSTRUCTIONS	17
UNFOLDING	19
FOLDING	23
USING THE BROMPTON ELECTRIC	27
GEARS	28
BRAKES	36
FRONT LUGGAGE CARRIER	39
REAR RACK	40
CLEANING THE BATTERY CONNECTON	41
ADJUSTING THE SADDLE POSITION	43
SADDLE HEIGHT INSERT FITTING	44
REAR WHEEL - REMOVAL AND FITTING	46
FRONT WHEEL - REMOVAL AND FITTING	48
ROUTINE REPLACEMENTS	50
WARRANTY	52

NOTE: The Brompton Electric Bicycle (Pedelec or electric bicycle) is referred to in this Manual as a bike, bicycle or Brompton, unless otherwise noted.

INTRODUCTION

READ ALL OF THE INSTRUCTIONS BEFORE USING THIS PRODUCT.

While this manual is intended as a guide, it is not a comprehensive guide to cycling or bicycle maintenance.



After purchasing your Brompton Electric bicycle, it is important to register your bike & battery in the My Brompton section of our website to record the details of your bike(s); that way, if your bike is stolen or we have any need to contact you, we will have a record to refer to. You will be asked to enter your serial and frame numbers: the serial number is located on a plate at the back of the main frame; the frame number is stamped on the main frame near the bottom bracket. The information remains on the Brompton database and will not be passed on to third parties <https://www.brompton.com>

If you carry out any adjustments or maintenance work yourself, please read the relevant sections of this manual first, as it's quite easy to get things wrong, and to impair the folding process or damage the bike and possibly make it unsafe to use. This manual contains some tips and advice for using your Brompton Electric but if you are ever unsure of how to maintain your bike, visit an authorised Brompton Electric dealer for expert advice. For a list of dealers, please visit our website: <https://www.brompton.com/Find-a-Store>

We recommend having your bike inspected and serviced by a Brompton Electric dealer regularly.

This manual conforms to **EN15194:2017 CPSC 16 CFR 1512**

CARRYING & WHEELING THE FOLDED BIKE

- Owners are responsible for assessing the way they use the bike at all times, and should ensure that they take due care of their safety and welfare when riding, moving or carrying their bike
- Brompton accept no responsibility for any injury caused when lifting and handling a folded bike
- A Brompton Electric bike weighs between 13.7 and 14.4kg, depending on the equipment fitted
- Luggage fitted to the mount on the front of the bike can also weigh up to 10kg, including the battery
- Luggage mounted to bikes equipped with a rear rack can weigh up to 10kg
- Owners must take due consideration of the weight of their bike, battery and any luggage they plan to lift or carry, and balance this against their particular physical capabilities; the circumstances i.e. route, under-foot conditions etc must also be considered before each lift and/or carry of the bike & luggage
- Owners should always remove the battery and luggage from the bike before folding
- Unfold the bike fully before refitting the battery and luggage; do not attempt to lift or carry the combined weight of the bike and luggage
- Whenever you are no longer able to ride your Brompton Electric, inside a train station for example, you should first push it as far as possible, then remove the luggage and battery, fold the bike and roll it on the rear rollers before carrying it for the shortest distance
- It is recommended that the folded bike is carried one-handed, most comfortably with your arm straight and the bike to your side. The bike should be held either by the saddle, or the main frame below the saddle, whichever is most suitable for you
- Carry the luggage and battery with the other arm, by the carry handle on the bag or shoulder strap
- If you have to carry the bike for any distance, then it may be appropriate to swap the bike and luggage between each hand at suitable intervals, depending on your capabilities
- Carrying the folded bike two-handed is only advisable over a very short distance, as it can only be done by holding the bike at chest/stomach level in order to avoid knocking your legs or knees against the bike; this requires both arms to be bent with an approx 90degree bend, which will place extra strain on your arms
- Turn off the Electric Assist System before walking with your Brompton Electric to avoid activating your motor. Knocking or moving your pedal when pushing your bike can cause the Smart Pedal Assist system to activate.

The small rollers fitted as standard on a Brompton Electric are useful for pushing the folded bike into tight spaces. Using the raised handlebar as a handle, the folded bike may also be pulled around on these rollers, though this only works over short distances on a smooth surface, the front luggage must **not** be attached to the bike when doing this. Remember to raise the seatpost slightly from the fully-down position so that it does not hinder the bike from rolling along, but not so high that the bike unfolds. The folded bike is not designed to be used as a stool, do not sit on the bike when folded.

INTENDED USE

The Brompton Electric is designed for use on roads and well-made paths, carrying a maximum load not exceeding 110kg (rider, luggage and battery weight included). A Brompton Electric is not intended for stunts, cross-country riding or extreme sports. Your Brompton Electric should be used for its intended purpose. Misuse may lead to failure of some components and void your Brompton Electric warranty. We do not recommend fitting a child seat or trailer to the Brompton Electric, doing so will invalidate the Brompton Electric warranty. The Brompton Electric is not compatible with indoor trainers or rollers, do not attempt to use the Brompton Electric in conjunction with these.

The bicycle is not intended for use at elevations greater than 2000m above sea level.

SPECIFICATION

This Brompton Electric bike complies with EN 15194 The motor assistance is limited to a maximum continuous power rating of 0.25 kW (250 W) and a maximum speed of 25km/h, (15.5 mph). The A-weighted emission sound pressure level at the driver ears is less than 70dB(A).

LUGGAGE WEIGHTS

- Brompton has a selection of front luggage compatible with the Brompton Electric. Standard front luggage is not compatible with the Brompton Electric
- The front luggage capacity of the Brompton Electric is 6.2kg, the bag and battery weigh up to 3.8kg
- This gives a maximum total load of 10kg for the front luggage
- The capacity of the rear rack (R-Version bikes only) is 10kg
- Ensure that when carrying luggage you do not exceed the maximum load for the bicycle (including luggage battery and rider) of 110kg
- Using incorrect luggage may interfere with steering and could be dangerous

SERVICING & SOFTWARE UPDATES

Your Brompton Electric should be serviced regularly by an authorised dealer.

We recommend having your Brompton checked by a qualified mechanic after the first 100 miles or 1-month (which ever comes sooner) as some items take time to bed in and may need adjusting to avoid damage.

Occasionally the software on your Brompton Electric will need updating, during regular servicing your Brompton Electric dealer will check for software updates and run diagnostics on the bike to ensure the electric assist system is working correctly. We may also contact you from time to time to let you know about any important updates.

You should ensure the bike is given a thorough service by an authorised Brompton Electric dealer at least once a year; you may need to increase the frequency of servicing depending on use and environmental conditions. Regular checks and maintenance will keep the bike working properly and increase the service life of components.

BLUETOOTH MODULE

This equipment has been tested and found to comply with the limits for a Class B digital device, pursuant to part 15 of the FCC Rules. These limits are designed to provide reasonable protection against harmful interference in a residential installation. This equipment generates, uses and can radiate radio frequency energy and, if not installed and used in accordance with the instructions, may cause harmful interference to radio communications. However, there is no guarantee that interference will not occur in a particular installation. If this equipment does cause harmful interference to radio or television reception, which can be determined by turning the equipment off and on, the user is encouraged to try to correct the interference by one or more of the following measures:

- Reorient or relocate the receiving antenna.
- Increase the separation between the equipment and receiver.
- Connect the equipment into an outlet on a circuit different from that to which the receiver is connected.
- Consult the dealer or an experienced radio/TV technician for help.

SAFETY

During use the casing of the electric motor will become warm, do not touch the motor casing when the bike is in use; if you need to remove the wheel to fix a puncture or similar, hold the wheel by the tyre and wheel rim. A warning label (shown opposite) is affixed to the hub motor, to signal the motor casing may be hot to touch.



WARNING - When using this product, basic precautions should be followed, including the following:

- Children under 14 should not ride this e-bike
- To reduce the risk of injury, close supervision is necessary when this product is used near children
- We recommend the use of an approved cycling helmet, even in countries where their use is not mandatory
- Before riding your Brompton Electric on open roads, please take time to familiarize yourself with the operation of the bicycle and electric assist system in a quiet place, away from traffic or hazards
- Ensure you do not drop the battery as it could cause injury or damage to the battery itself
- Please fully charge the battery before the first use
- Ensure that the battery, front bag and bag strap are properly secured before using the bike
- Do not try to operate the user interface on the battery when riding
- Read and follow the national legal requirements of the country where you are riding in relation to cycling, bicycles and electric assist bicycles, and comply with all applicable traffic laws
- Make sure the wheel rims are clean and undamaged along the braking surface, and check for excess rim wear; if you doubt the safety of your rims, have them inspected by an authorised Brompton Electric dealer
- Check brakes, tyres (including tyre pressure) and steering regularly
- Keep brakes and gears properly adjusted and operating cables in good condition
- In rain, the brakes may be less effective and roads more slippery so brake sooner
- In rain, the road surface will offer less grip, use caution, reduce speed and stop pedalling when riding over drain covers around corners etc.
- Check that all wheel nuts are properly tightened (see torque table, page 27)
- In the UK, the left hand brake lever operates the rear brake and the right hand lever operates the front brake, the orientation for other countries is shown below before riding ensure you know which way the brakes are orientated.



UNITED KINGDOM	LEFT - REAR / RIGHT - FRONT
FRANCE, ITALY, SPAIN, PORTUGAL, GERMANY, NETHERLANDS, BELGIUM, USA	RIGHT - REAR / LEFT - FRONT

- When riding in the dark, wear reflective clothing and use lights (front and rear); check to ensure that your lights comply with local laws
- Do not wear loose-fitting or trailing clothing, that could become snagged or trapped in the bicycle during use
- Once you have read the manual, please consult your Brompton Electric dealer who will be able to assist with any further questions you may have
- Do not use the Brompton Electric if there is any problem with the power assist system, take the bike to an authorised Brompton Electric Dealer for inspection
- When stopped do not apply pressure to the pedals, this could engage the power assist function
- It is also advisable to apply the brakes when stationary as well as to turn off the power assist system

Before or after each ride, pay close attention to the following:

- Ensure that the quick release seatpost clamp is secured and the saddle is at the correct height
- The hinge clamps are in place, with levers firmly tightened
- During folding and unfolding, as well as during use and maintenance, avoid putting your hands or fingers anywhere they may be caught or trapped
- Remove the battery and front bag from the bike when carrying out any maintenance on the bike
- Ensure the bike is correctly folded or unfolded to avoid possible injury
- Ensure the battery and luggage are properly secured to the front of the bike and that the connector block is properly fastened to the bike before use
- Ensure the front luggage strap is properly secured so that it is not able to come loose, a loose luggage strap could obscure the lighting system or become caught in the wheel
- Ensure the battery and luggage are removed from the bike before folding
- Never try to alter the height of the handlebar stem where it enters the front forks,
- Do not alter the angle and position of the handlebars where they attach to the handlebar stem, this will compromise the folding function of the bike and the handling
- **SAVE THESE INSTRUCTIONS**

WARNING

Many components on a bike are highly stressed, and with high mileage, heavy loads or hard riding, will eventually reach the end of their design life; in particular, aluminium alloy has a limited fatigue life. Failure in use can cause injury. You should check all load-bearing parts for any signs of damage, corrosion, or cracking, and replace if necessary. Please visit an authorised Brompton Electric dealer for expert advice if you are uncertain. Regular servicing and inspection of the bike by a Brompton Electric dealer is advised.

As with mechanical components, the electrical assist system including the battery and motor, is subject to stress and wear. Different materials will react to stress fatigue and wear in different ways. If the design life of the component has been exceeded it may not function correctly or fail suddenly. Any changes to the appearance of colour of a part, or signs of cracking etc. could indicate the lifespan of the part has been exceeded and it should be inspected and replaced by an authorised Brompton Electric Dealer.

The bike must not be subject to any modification, repair or replacement other than as authorised by Brompton Bicycle Ltd, this includes but is not limited to the components listed below in the 'replacement parts' section. The electrical system including the software should not be modified or tampered with, the hub-motor, control module and battery should not be opened, tampered with or modified in any way.

The bike must be serviced at regular intervals by an authorised Brompton Electric Dealer. If the bike has been subject to a crash or impact you should stop using the bike immediately and have the bike inspected by a Brompton Electric dealer. Damaged components should be replaced and the bike thoroughly checked before the bike is ridden again. Any deep scratches or gouges in the aluminium parts can severely weaken the component and cause premature failure of the part.

We recommend that genuine Brompton parts are used for safety-critical components

REPLACEMENT PARTS

The following parts of your Brompton Electric bike should only be replaced with genuine Brompton Electric parts, by an authorised Brompton Electric dealer:

- Front wheel/motor
- Bottom bracket
- Front battery connector/mount
- Charger
- Electric system cabling
- Battery pack
- Brake pads
- Braking system components
- Luggage frame
- Suspension block
- Fork
- Mainframe
- Handlebar stem
- Rear frame
- Cranks
- Chainring
- Pedals
- Hinge clamp plates

Only Genuine Brompton Electric parts should be used for safety-critical components. Using replacement parts other than those specified as original equipment on the bike may cause problems with the function of the bike or make the electric bike unsafe to use.

Changing the Drivetrain components, including the cranks, chainring and pedals will affect the performance of the electrical assist system, such changes should only be made by an authorised Brompton Electric dealer.

If the Brompton Electric is modified in any way it may not then conform to the relevant safety standards. Using the bike in a modified state may be dangerous and could cause injury and damage to property.

The bike must not be subject to any modification, repair or replacement other than as authorised by Brompton Bicycle Ltd, this includes but is not limited to the components listed below in the 'replacement parts' section. The electrical system including the software should not be modified or tampered with, the hub-motor, control module and battery should not be opened, tampered with or modified in any way.

BROMPTON



**UK
CA**

UK DECLARATION OF CONFORMITY

The Manufacturer: Brompton Bicycle Ltd.
Unit 1, Greenford Park
Ockham Drive, Greenford
Middlesex UB6 0FD
UK

Hereby declares the following product(s):

Product Description: Brompton Electric
Model Designation: Brompton Electric C and P Lines

Year of Manufacture: 2024 or later

Serial number range: Please refer to first four digits of serial number (YYMM)

To be in compliance with the essential requirements of the following UK Regulations:

Supply of Machinery (Safety) Regulations 2008
Electromagnetic Compatibility Regulations 2016

And that the following designated standard(s) were applied in the conformity assessment:

Cycles – Electrically Power Assisted Cycles – EPAC Bicycles – BS EN 15194:2017

Technical file contact address: Brompton Bicycle Ltd.

Unit 1, Greenford Park
Ockham Drive, Greenford,
Middlesex UB6 0FD, UK

Authorised signatory on behalf of Brompton Bicycle Ltd.:

Will Butler-Adams O.B.E.
Chief Executive Officer
Brompton Bicycle Ltd.

9th April 2024

ITEMS SUPPLIED WITH YOUR BROMPTON ELECTRIC (GREENWAY BATTERY)

In addition to the bicycle and this manual you will receive the following items, if any of these are missing, please contact your Brompton Electric dealer.

ATTENTION: FULLY CHARGE THE BATTERY BEFORE FIRST USE.

BATTERY: DZ-ZZ1481002

Manufacturer: Guangdong Greenway Technology Co., Ltd.

- Rated capacity - 9.6 Ah
- Power - 354 W
- Internal resistance - 142.89 mΩ
- Energy round trip efficiency - 99.67%
- Expected life-time of the battery - After 500 cycles the battery shall have about 70% -80% capacity

BAG - This bag is designed to house the battery and fits to the mounting block on the front of the bike.

CHARGER & MAINS ADAPTOR - The standard 2A charger is supplied with each Brompton Electric, along with the appropriate mains adaptor for the region the bike is sold in.



Battery x1
Battery Bag x1

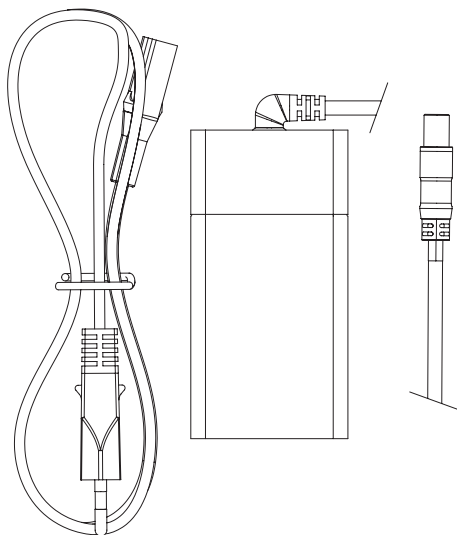

Battery Charger x1

FITTING/REMOVING THE BATTERY & BAG

To fit the battery and bag onto the bike, align the connector on the bottom of the battery with the connector on the front carrier block, and slide it on. The connector cover will automatically lift up, and the battery carrier frame latch will click into place. Lightly pull on the battery handle to ensure that it is securely in place before riding.

To remove the battery and bag, hold the button next to the handle on top of the bag frame, the battery carrier frame latch will retract, and you can lift the battery/bag off the bike.

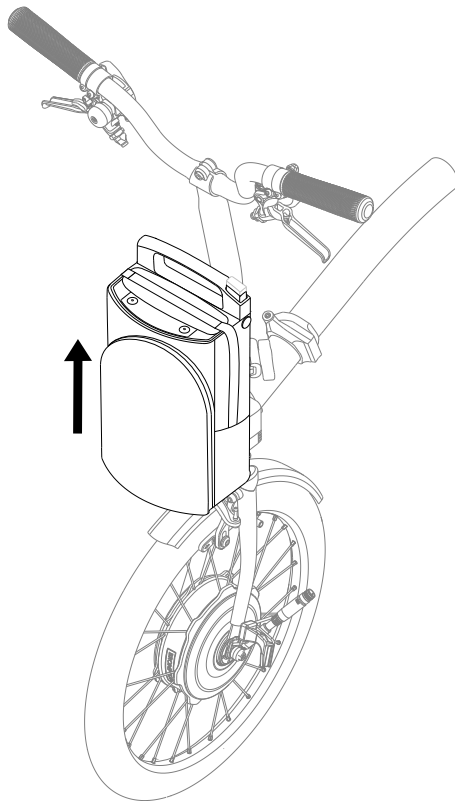
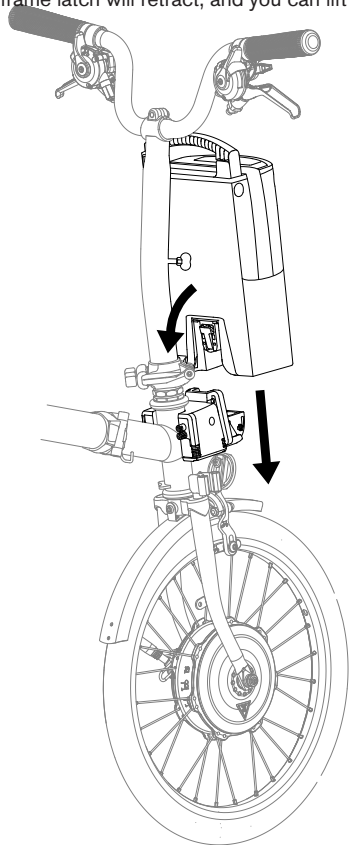

FITTING/REMOVING THE BATTERY FROM THE FRAME

The button which removes the battery from the frame can be found underneath the frame handle. Depress this button and lift the battery handle.

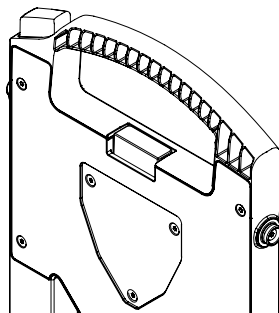

DOWNLOAD THE BROMPTON APP

The bike is bluetooth enabled, download the Brompton app for further features. Scan the QR code using your mobile phone camera or a QR scanner to take you to the download link for the Brompton app.

THE ELECTRIC ASSIST SYSTEM

The Brompton Electric gives motor assistance to support the pedaling input from the rider.

A sensor in the bottom bracket measures the rider's cadence* and torque, a sensor within the hub motor measures the speed of the bike. The system analyses this data to determine how much assistance the hub motor gives. The system is constantly checking the rider input and matching the power assistance accordingly. The maximum continuous power output from the motor is 250W and the motor is restricted so that it will not give assistance beyond 25km/h.

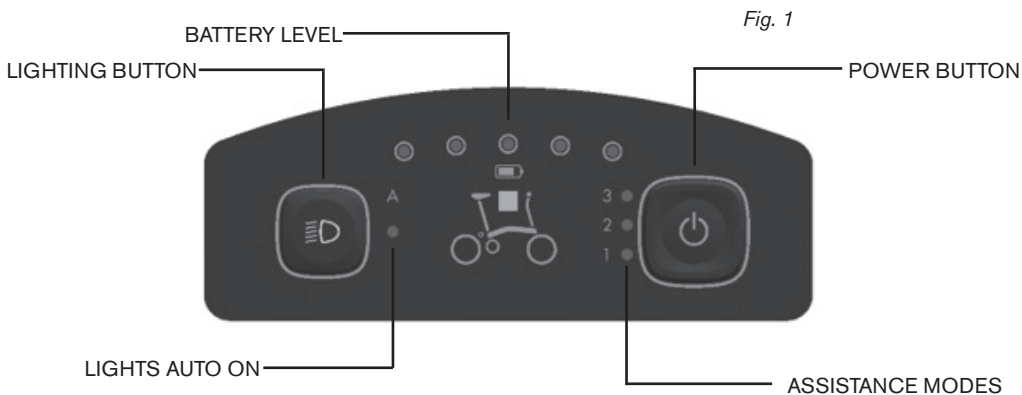

OPERATING INSTRUCTIONS

The electric assist system is controlled using the panel on the top of the battery (fig. 1) and this can be used to set the power and lighting modes, as well as showing the battery level. You should only operate the system when stationary, do not attempt to use the controls when riding. These can also be controlled from the app.

- To turn on the system, press and hold the power button until the battery level display lights-up
- To turn the system off, press and hold the power button until the lights on the display are no longer illuminated
- The system will automatically switch-on when the battery/bag is fitted onto the connector block on the front of the bike
- When you turn the system on, or it powers-up when fitted onto the bike; it will default to the last assistance mode used
- After the bike has been stationary for 5 minutes (without the wheels or pedals moving) the system will turn itself off

The assistance can be set by selecting one of the four available modes from zero to three. You can cycle through the assistance modes when the system is turned on, by pressing the power button repeatedly.

The higher the assistance mode the more quickly the battery power will be used.

- 0: No assistance
- 1: Low assistance, high range
- 2: Medium assistance, medium range
- 3: High assistance, lower range

*Cadence is the number of revolutions of the pedals per minute

BATTERY LEVEL (WHEN CHARGED TO 100%)

ATTENTION: FULLY CHARGE THE BATTERY BEFORE FIRST USE.

The battery level indicator has 5 lights which show the level of charge (fig. 2). When the battery is switched on and connected to the bike the battery indicator will be illuminated.

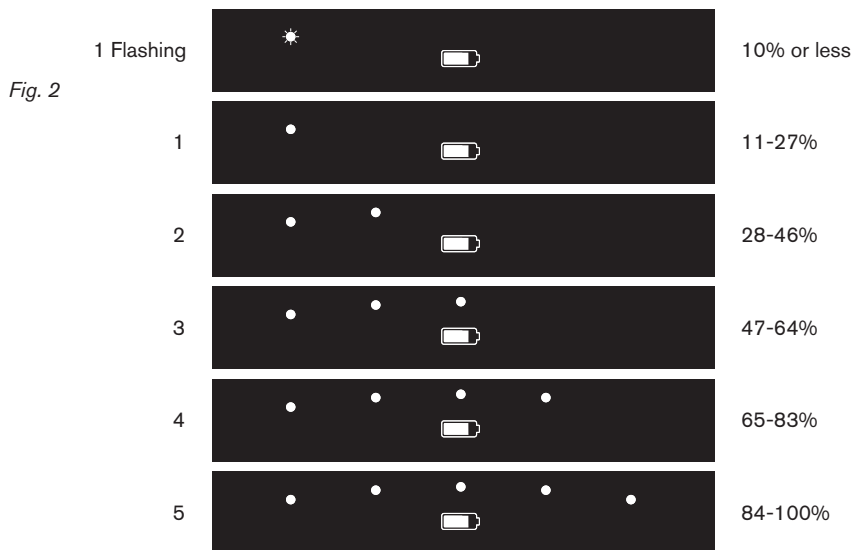

Do not attempt to operate the battery user interface while riding

BATTERY RANGE

The battery range is typically 30km to 70km (~20mi to ~45mi), this can be affected by a number of factors. Take these into account to maximize the range. Information on battery care can be found on page 17.

ASSISTANCE MODE

The higher the assistance mode the more battery power is used; to improve the battery range, lower the assistance mode where possible.

TYRE PRESSURE

Keeping your tyres properly inflated will reduce the rolling resistance of the bike and mean that both the rider and the electric assist need to use less energy, this will improve the battery range in comparison to under inflated tyres. For more information on tyre pressures please see page 27.

STARTING AND STOPPING

Routes which require you to start and stop often (such as city riding with lots of junctions) will use more battery power than routes with more continuous riding.

WIND CONDITIONS

If riding into a headwind, a greater amount of power will be needed to maintain the same speed. Similarly a tailwind will reduce the amount of power used.

CADENCE

The system will work with a wide cadence range, very low cadences will force the motor to work harder and use more power; try using different gears to alter your cadence and find what works best for you.

TEMPERATURE

The efficiency of the battery will reduce at low temperatures, so you might experience improved range in the summer compared to the winter. The optimum operating temperature is around 20 degrees Celsius.

HILLS

Riding up hill will use more power and reduce the range, riding downhill will use less power.

WEIGHT

The weight of the rider and luggage will have an effect on the battery range, decreasing the load by carrying less nonessential items of luggage will allow you to improve the battery range.

CHARGING THE BATTERY

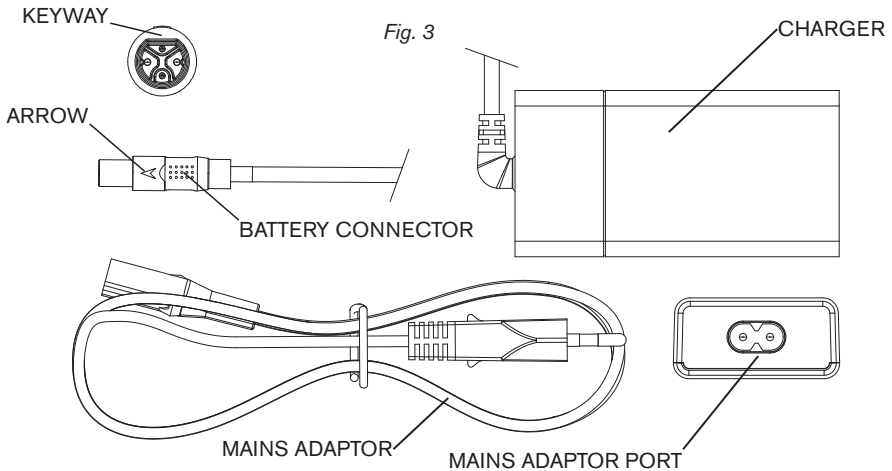

It is possible to charge the battery when mounted onto the bike or with the bag removed from the bike, or with the battery on its own, removed from the bag. If the bike is stored in a cold place, it's best to bring the battery into a warm room to charge. Ensure that the battery and the charger is completely dry before charging.

Place the battery and charger onto a level surface, where they cannot be knocked or damaged and which is non-flammable. Connect the mains adaptor to the port on the charger (fig. 3) you should use a mains adaptor appropriate to the country you are in.

The charging port on the battery (fig. 5, 6) is located on the rear bottom left hand corner of the battery pack behind a protective rubber cover. Lift the cover upwards, from the bottom edge to expose the battery connector port. Once you have finished charging, remove the charger and ensure the port cover is properly closed.

The battery connector cable has a keyway (fig. 3) which must be lined up to the corresponding feature at the bottom of the connector port on the battery. Correctly orientate the keyway and firmly but carefully push the connector onto the battery.

USING THE CHARGER

It is important to use the charger and battery together in the correct order.

1. Plug mains adaptor into the charger (fig. 3).
2. Plug mains adaptor into wall socket (fig. 3).
3. Plug charger into battery port. The white arrow on the battery connector should be orientated on top (fig. 5).
4. Before storing, remove the mains adapter from the charger (fig.3).

The charger and charging cable should be routinely checked before use. Do not use if any part of the charger is frayed, has broken insulation or any signs of damage.

CHARGER STATUS

- When the charger is first plugged in/turned on, the green light is permanently on
- When connected to the battery and mains the red light will be permanently on, to show the battery is charging
- When the red light turns to green, the battery is fully charged
- If the red warning light is flashing, there may be a problem with the charger, try turning off the mains power, unplug the charger and then plug the charger in and turn on the mains
- If the red warning light continues to flash, unplug the charger and stop using it, contact your Brompton Electric dealer for further assistance
- The charger has an overload, short circuit, over voltage, wrong polarity and charger over-temperature turn off protection; this will be indicated by the charger flashing red

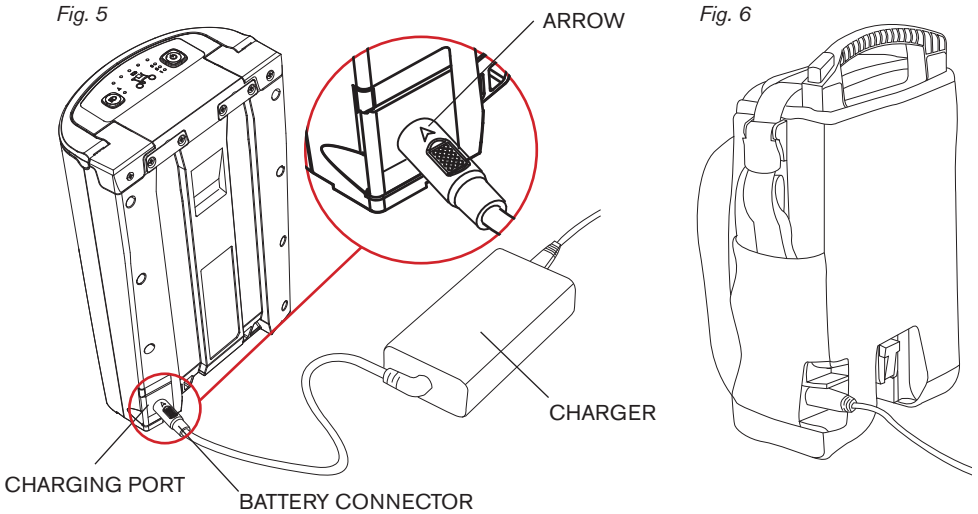

CHARGING LEVEL (WHEN CHARGED TO 100%)

The battery level indicator (fig. 7) has 5 lights, when charging this will indicate the level of charge as shown below.

Fig. 7

0-1		10% or less
1-2		11-27%
2-3		28-46%
3-4		47-64%
4-5		65-83%
5		84-100%

When the battery is fully charged the display will show all five battery level lights fully illuminated, then the charger light will change from red to green, and after a short time the battery display will turn itself off. Once the battery is fully charged, or you have finished charging the battery; unplug the charger from the mains socket and the battery. Ensure the rubber cover on the battery connector is pushed back into place. The battery and charger may become warm when charging, take care when handling them. If the charger or charging cable becomes damaged, do not use the charger and have it inspected by an authorised Brompton Electric dealer.

CHARGING TIME

It takes around 4 hours to charge the battery to 80% charge, from fully discharged. It takes around 5.5 hours to charge to 100% from fully discharged.

When the battery is connected to the charger and fitted to the bike, do not move the bicycle. this could result in the charger, cable or connector becoming tangled in the bike, pinched or damaged in some way. When stopped do not apply pressure to the pedals, this could engage the power assist function. It is also advisable to apply the brakes when stationary as well as to turn off the power assist system.

ERROR CODES

In some cases, if there is a problem with the electric assist system, an error code (fig. 8) will be displayed on the battery level indicator. If the display is showing an error code it means the system will not be powering the motor or giving any assistance. Depending on the error code you may be able to take steps to remedy the problem; otherwise the bike will need to be returned to your Brompton Electric dealer for diagnosis.

If the battery is too low to power the motor, you will need to recharge the battery. This will be shown by the left hand light flashing.

If the right hand light is flashing, reset the system by turning it off and back on with the power button. If this does not clear the error, contact your Brompton Electric Dealer.

Error A indicates a motor problem and is shown by the two lights on the right flashing. The motor is not user serviceable and you should contact your Brompton Electric dealer who will be able to diagnose the problem and rectify it.

Error B indicates a battery issue and is shown by the centre and right hand lights flashing. The battery is not user serviceable and you should take the bike to your Brompton Electric dealer for diagnosis.

Error C shows an issue with the controller, again this is non user serviceable and you should take the bike to your Brompton Electric dealer for diagnosis.

Battery is cooling down. In this case, the battery will begin to charge once the battery reaches the adequate temperature.

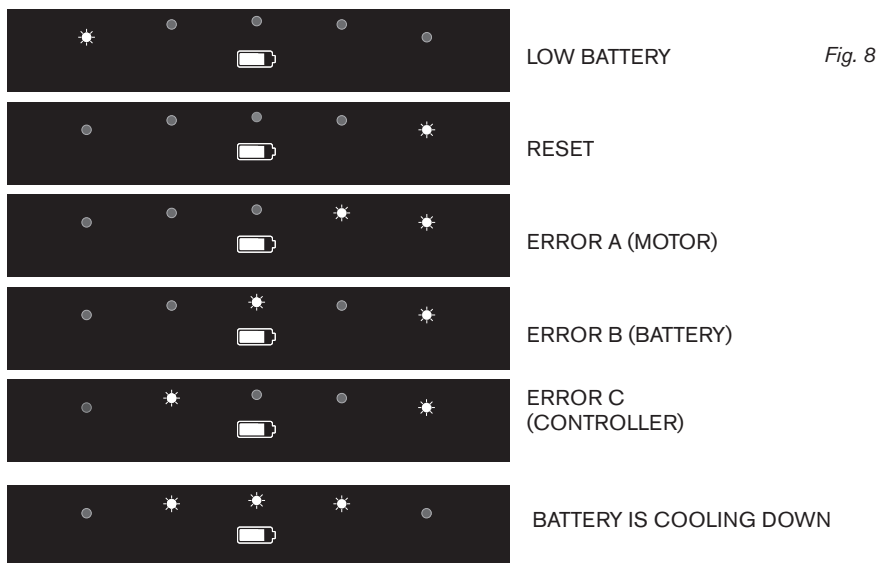

USING THE LIGHTING

Fig. 9

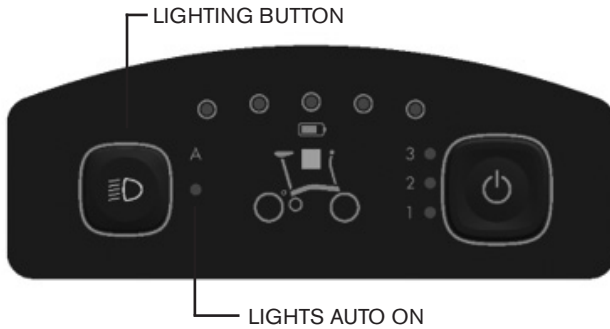

- Pressing the lighting button will change the lighting mode. In daylight, the light button being illuminated indicates lights on mode, the automatic lights mode is selected when the 'A' position is illuminated.
- To cycle between the ON and Automatic lighting modes, press the lighting button
- When turning the system on with the power button, the lighting will default to the last setting used before the system was switched off
- The Automatic light mode uses a sensor on the top of the battery; if the bag strap is not properly secured in position it could obscure the sensor and stop the lighting from automatically switching off in daylight
- Before riding at night be sure to check the battery power level, to ensure there is sufficient charge to power the lighting system for the duration of your ride. Do not ride at night without lighting
- As a safety feature, the lights will last for around 2 hours after battery dies. In case of this failure, the lights and battery are operative for 15 minutes and the battery will turn off after that period

Do not attempt to operate the battery user interface while riding

MAINTENANCE INSTRUCTIONS

In order to get the maximum life from your battery you should take care to use, store and recharge it correctly. We do not recommend completely discharging the battery on a regular basis; this will reduce the capacity and lifespan of the battery. If the battery becomes fully discharged, recharge as soon as possible. We recommend charging the battery at least once a month.

Over time the capacity of the battery will reduce, eventually the battery may need replacing. The service life of the battery will vary according with usage. The old battery should be disposed of responsibly, in accordance with local regulations. Please take the old battery to an authorised Brompton Electric dealer, who will be able to assist you in disposal and obtaining a replacement.



The battery should always be used in conjunction with a compatible Brompton Electric bag, do not attempt to use the Brompton Electric battery without the front luggage.

CHARGING

The battery should be charged indoors in dry conditions and at room temperature only using the Brompton battery charger. This can be done with the battery and bag attached to the bike, in the bag separately from the bike, or the battery on its own. Follow the instructions contained on the label affixed to the Battery and battery charger. Once the battery is charged and the charger cable removed, ensure the rubber charging port cover on the battery is properly closed and unplug the charger from the mains electricity supply. Keep the battery and charger out of direct sunlight when charging.

STORAGE INSTRUCTIONS

If you intend to store the battery without use for an extended period of time, we recommend first charging it to 47-64%, this is shown by 3 lights on the indicator. This will reduce the amount the battery discharges over time. Do not store the battery for long periods when fully charged or fully discharged. The battery should be stored in a dry location and away from sunlight, in a temperature range above 0 °C (32°F) and below 20 °C (68°F), the optimum storage temperature is 10 °C (50°F), the optimum storage humidity is ≤50%RH. It is recommended to charge the battery to full at the beginning of using the battery after a long period of storage and to then drain it completely.

CLEANING & CARE

Remove the battery before cleaning & maintaining the bike. Do not use a jetwash or hose to clean the bike or the battery. This can force water into the motor, battery and electrical components; damaging them and causing them to function incorrectly. Do not use solvents, aerosol cleaners or degreasers to clean the bike. For best results clean the bike with warm soapy water and a sponge. Keep the battery dry, wipe the battery down with a dry cloth to clean it.

Do not submerge the bike, hub motor or battery in water; this can allow water to enter the motor, battery and electrical systems. This could cause overheating bursting or ignition. Do not place the battery or bag down on a wet floor, this could allow water onto the battery connector.

Exposure to humid conditions, marine environments or salinity of any kind can cause corrosion of the bicycles components, frame parts and fasteners. This can cause cosmetic damage and also shorten the lifespan of the parts. Clean the product regularly and store in a dry environment to avoid corrosion of the parts.

TEMPERATURE

During cold weather we recommend charging/storing the battery indoors at room temperature before attaching the battery to the bike for riding. Do not charge the battery in a temperature below 0 °C (32°F) or above 45 °C (113°F). After the bike has been used in cold weather, ensure the battery has been indoors for at least an hour before charging; this will allow it to reach room temperature. Do not charge when the battery is cold. The battery should always be used in conjunction with a compatible Brompton Electric bag, do not attempt to use the Brompton Electric without the front luggage. The bicycle is designed to work in a temperature range of 0 °C (32°F) to 40 °C (104°F), outside of this temperature range the product may not function correctly.

MOVING INSTRUCTIONS

If transporting the bike in a car or on public transport, remove the battery/bag from the bike. The battery should be kept away from moisture and direct sunlight. If you need to take your Brompton Electric on a train or other forms of transport; please check with the service provider before you travel for advice on any restrictions on the transportation of lithium batteries. It is not permissible to take the battery on a commercial aircraft. Always disconnect the battery and bag from the bike when transporting your Brompton Electric. Batteries must not be shipped without special packaging and labelling by a forwarding agency or package service.

WARNING: INSTRUCTIONS PERTAINING TO RISK OF FIRE or ELECTRIC SHOCK

Do not open the battery case, modify or deform the case; do not attempt to modify the battery connector in any way. Doing so may cause leaking, overheating ignition or bursting of the battery, which could result in serious injury or damage to property.

If the battery is damaged in any way, do not attempt to use or charge the battery, contact your Brompton Electric dealer immediately.

Do not leave the battery near heat sources or fire, or apply heat or flames to the battery. This could cause bursting or ignition of the battery, which could result in serious injury or damage to property.

Do not leave the battery in direct sunlight or in an area that is likely to become hot when exposed to direct sunlight, such as in a parked car etc.

Do not subject the battery to impact, throw or shock the battery, this could cause overheating bursting or ignition of the battery, which could result in serious injury or damage to property.

Do not submerge the battery in water and do not allow the battery terminals to become wet, this could cause overheating bursting or ignition of the battery, which could result in serious injury or damage to property.

Only use the supplied charger or chargers authorized for use by Brompton Bicycle Ltd. to charge the battery, using an unauthorized charger could cause overheating bursting or ignition of the battery, which could result in serious injury or damage to property. Follow the charging instructions and take notice of the charging instructions.

If the charger or charging cable becomes damaged, do not use the charger and have it inspected by an authorised Brompton Electric dealer.

The bicycle should be indoors when charging or not riding.

Prolonged exposure to UV rays, rain and the elements may damage the enclosure materials, store indoors when not in use.

The bicycle is not intended for use at elevations greater than 2000 m above sea level.

UNFOLDING THE BIKE

Take some time to look at the bike folded; it helps when you come to fold it again.

2. Insert pedal - P Line

Insert the detachable pedal into the quick release pedal mount by pushing the hex shaped axle of the detachable pedal into the mount, whilst twisting to align the axle to the inside of the mount. Apply pressure until there is a click to indicate that it is fully inserted.

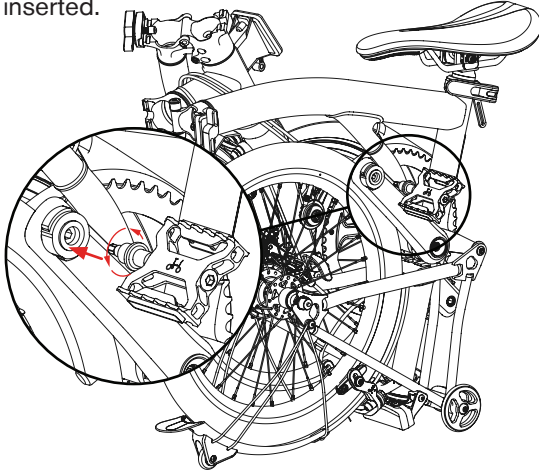

C Line

Stand on the left (non-driveside) of the bike. Unfold the left-hand pedal by pulling the toothed metal cage towards you. As you do this note how the black catch operates as this will help you when folding.

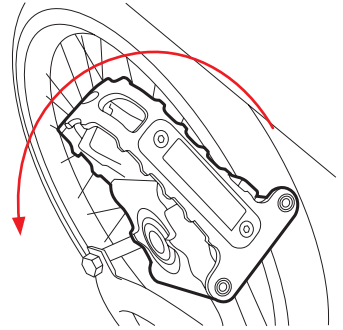

3. Unfold handlebar

To release the handlebar, firmly push down on the end of the grip nearest to you with your left hand. Swing the handlebar up until the hinge closes.

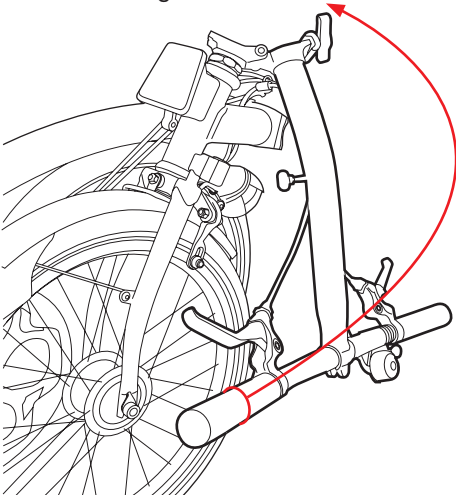

4. Tighten hinge

Once the hinge is closed, the black clamp lever can be closed firmly.

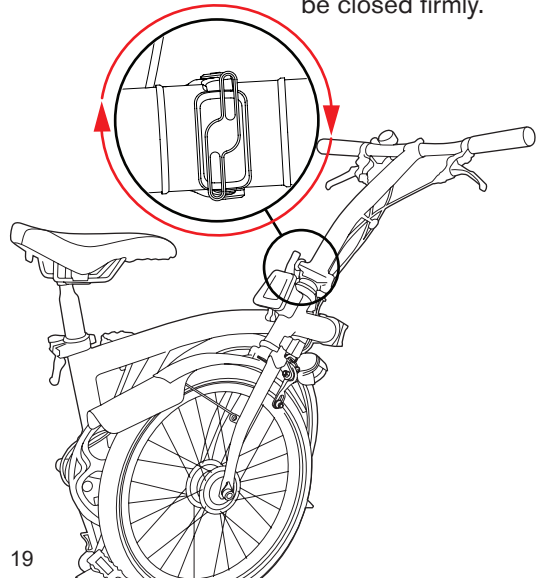

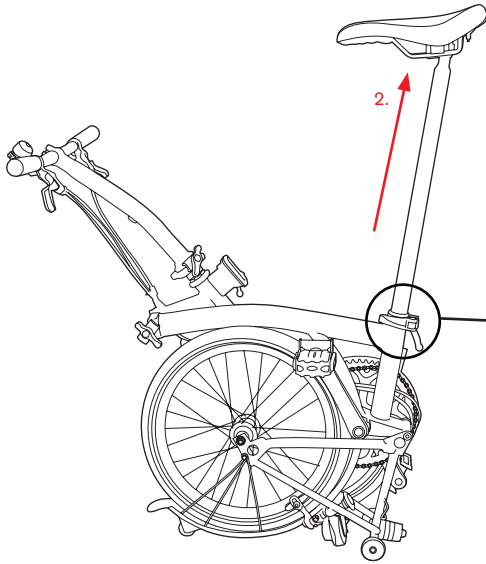

5. Raise saddle

Undo the seat clamp lever, pull the seatpost up and re-clamp to secure the seatpost.

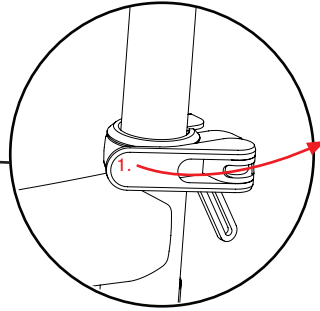

6. Lift to unhook

Place your right hand on the saddle and hold the handlebar stem with your left hand, near the hinge.

Look down where the chain runs between the two wheels and you will see the black hook holding the front wheel to the rear frame.

Lift the handlebar stem with your left hand, to lift the hook above the tube it is resting on.

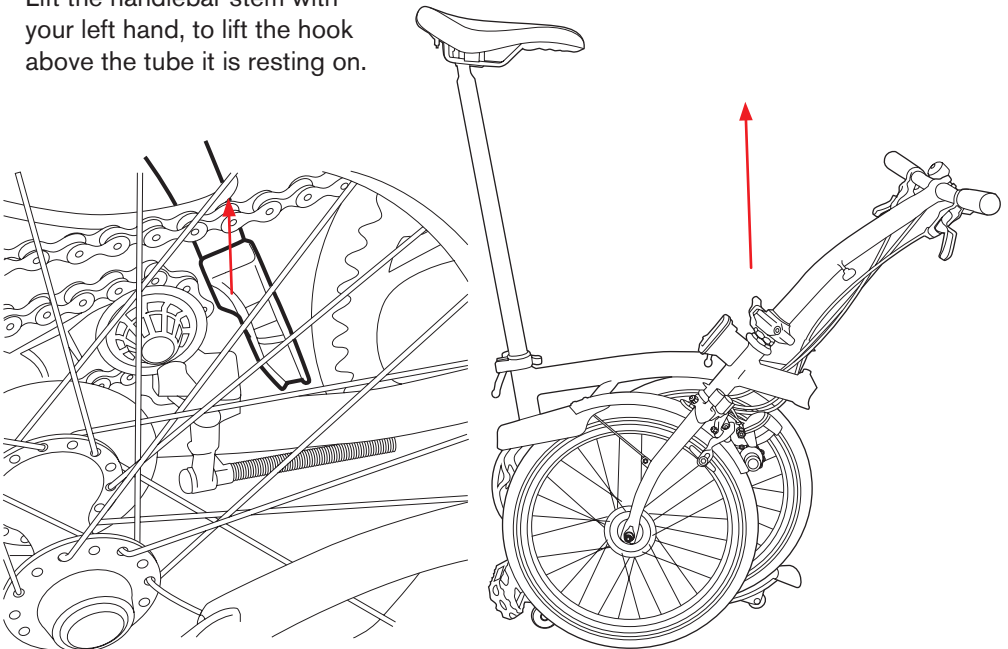

7. Unfold front wheel

Swing your left hand away from you in an arc to push the fork and front wheel away from you, push until the hinge on the main frame is closed.

When doing this ensure that the front wheel remain pointed in a forward direction, the hook must also remain on your side of the bike.

At the end of this step, the front wheel should be pointing forward at a slight angle, not parallel with the rear wheel.

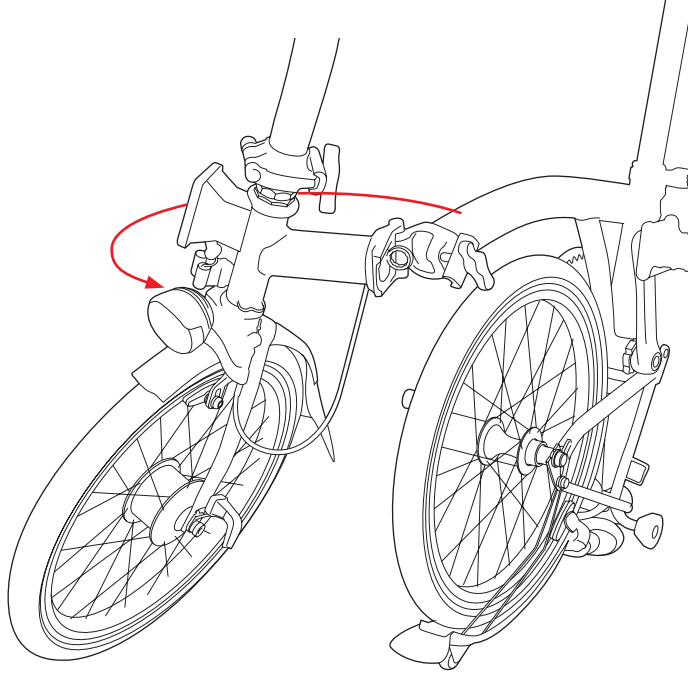

8. Tighten hinge

The hinge on the main frame should now be closed by tightening the black clamp lever firmly.

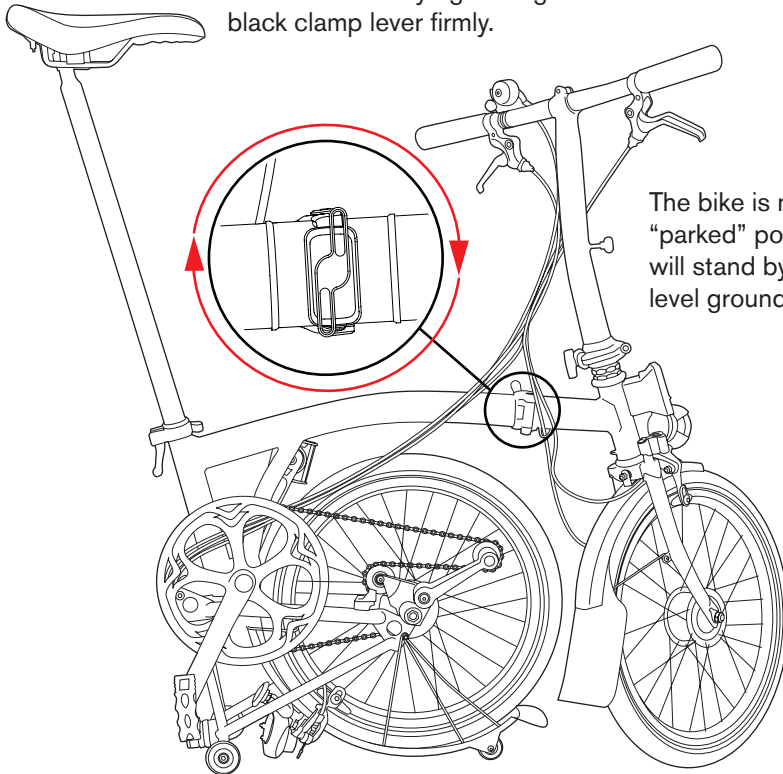

The bike is now in its “parked” position – it will stand by itself on level ground.

9. Unfold rear wheel

To complete the unfold, hold the handlebar with your left hand, and with your right hand lift the rear of the bike up swiftly by the saddle and swing the rear wheel backwards into position.

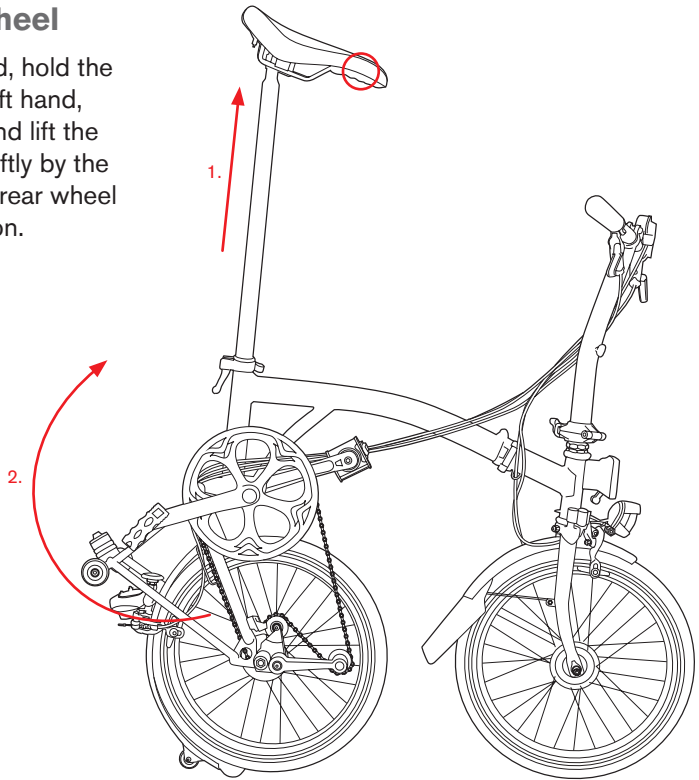

10. Unfolded

Push down on the saddle to ensure the suspension block pushes against the mainframe.

You can now connect the battery and front luggage to the bike

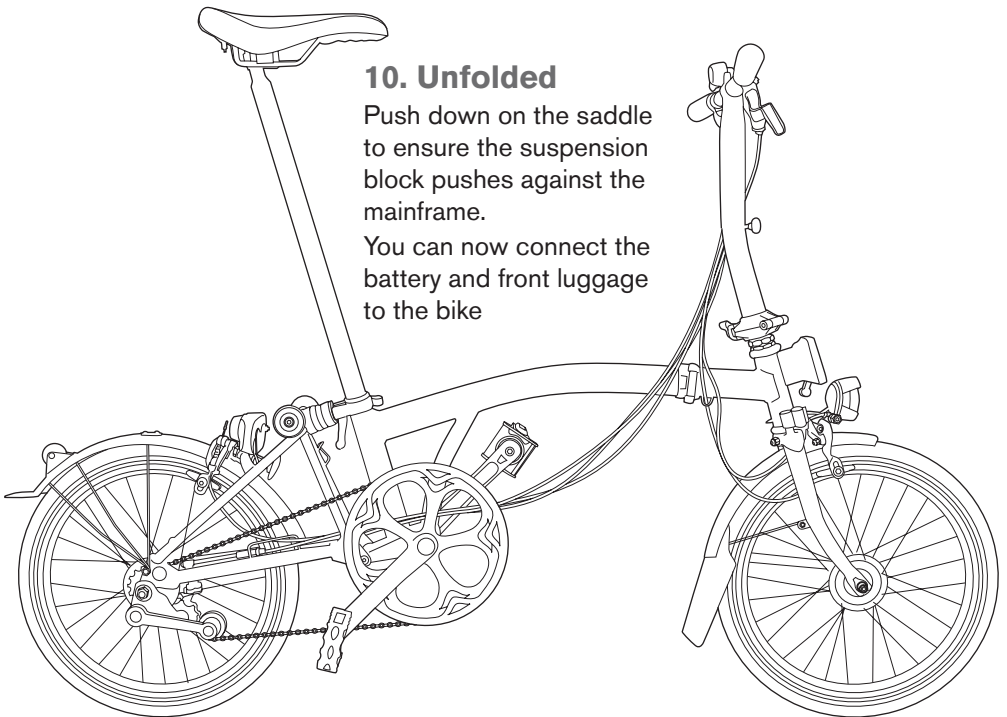

FOLDING THE BIKE

1. Spin cranks

Stand on the left (non-driveside) of the bike. Spin the cranks so the right-hand pedal is pointing towards the back of the bike.

Turn the handlebar slightly to the left so it is not parallel with the rear wheel.

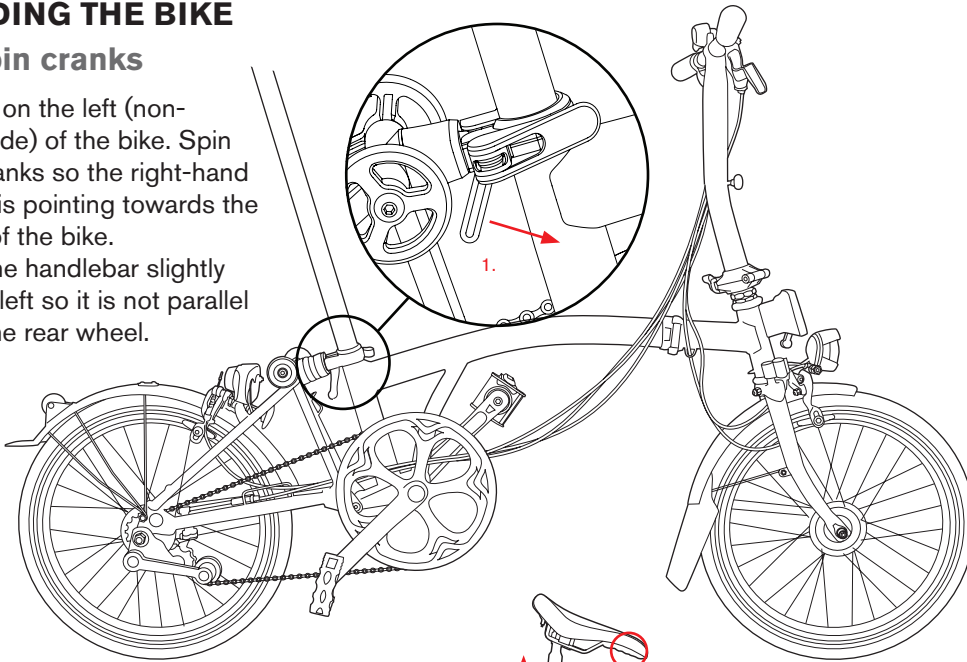

2. Fold rear wheel

1. There is a lever directly below the seat clamp. Press it forward.

2. lift the saddle of the swiftly

3. Allowing the rear wheel to swing under the main frame.

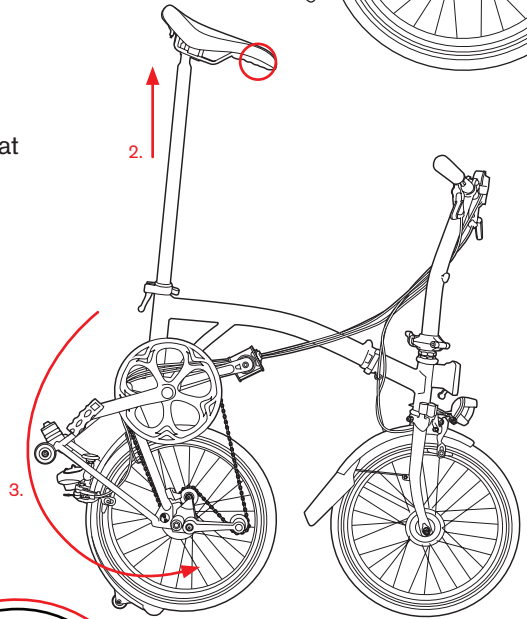

The bike should now be in the “parked” position – it will stand by itself on level ground.

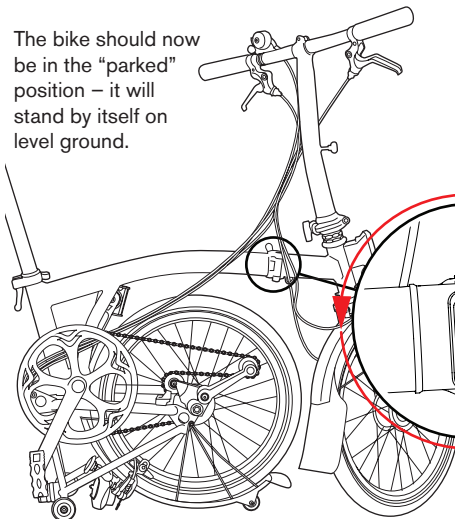

3. Undo hinge

Undo the hinge clamp lever on the mainframe in preparation for the next step.

4. Fold front frame

With your left hand, hold the handlebar stem below the handlebar. Swing the front wheel away and to the right, bring the handlebar stem round in a clockwise stirring motion. When doing this, make sure to keep the front wheel pointing in the forward direction, the hook must remain on your side of the bike.

Do this until the front wheel is alongside the rear wheel, and the hook located on the front fork can hook on the rear frame. You may need to slightly lift the front of the bike.

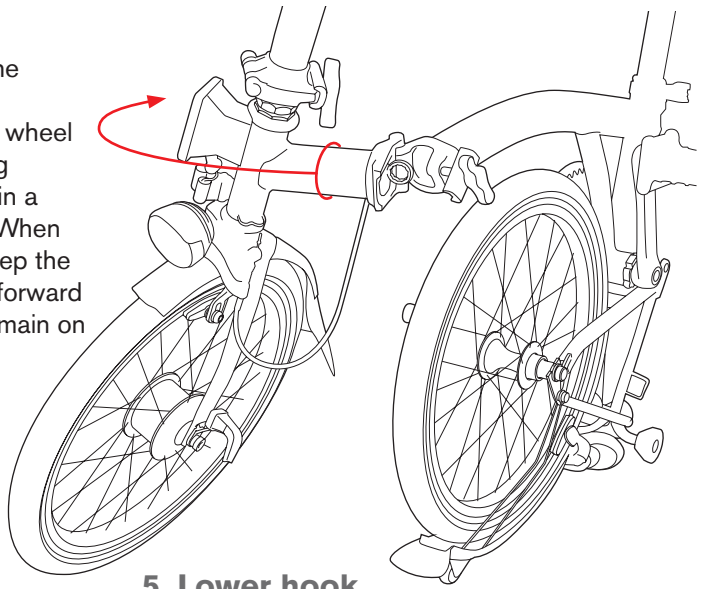

6. Undo hinge

Undo the hinge clamp lever on the handlebar stem by 4-6 turns.

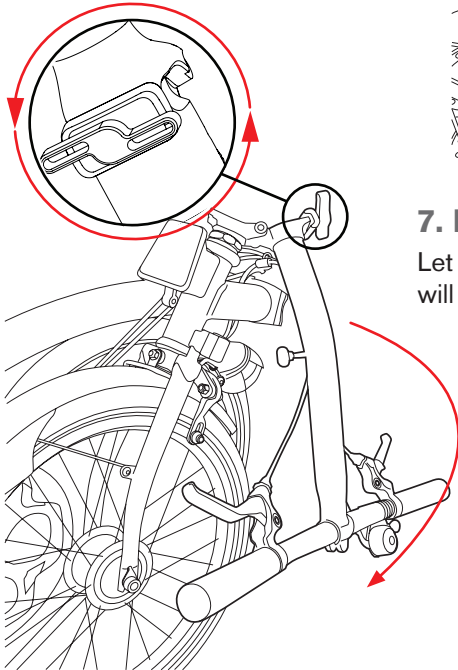

5. Lower hook

Lower the hook over the chain stay located on the rear frame.

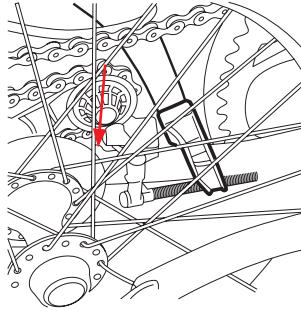

7. Fold handlebar

Let the handlebar stem fall down. The nipple will secure it in place.

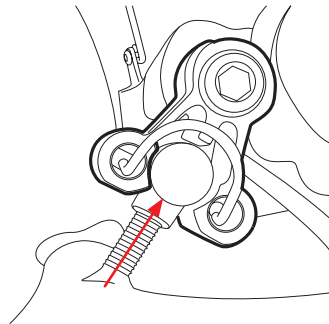

8. Lower saddle

Undo the seatclamp and lower the saddle fully. This locks the bike together, so it won't open up when carrying. Close the seat clamp lever once saddle is lowered.

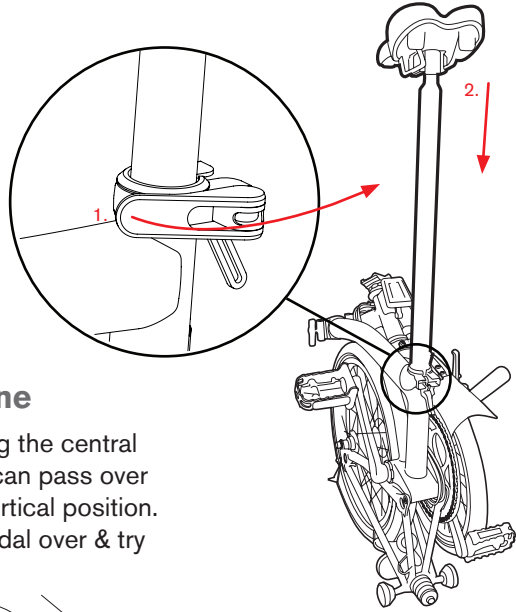

9. Folding the pedal - C Line

Fold the left hand pedal, by pressing the central black plate upward, enough that it can pass over the end of the crank arm & into a vertical position. If you can't lift the plate, turn the pedal over & try again

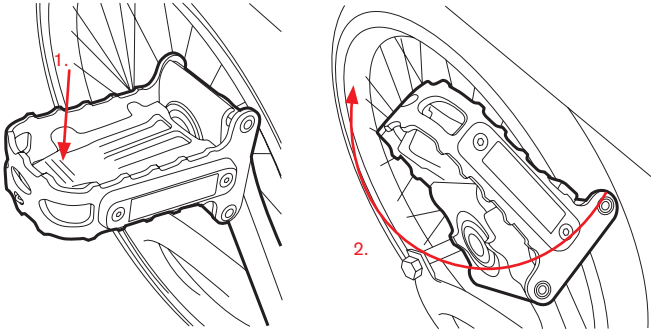

Storing the pedal - P Line

Remove the rubber cover from the pedal holder on the rear of the front fork. Place the detachable pedal in the pedal holder and twist slowly when inserting to correctly line up the hex shaped axle to the inside of the holder.

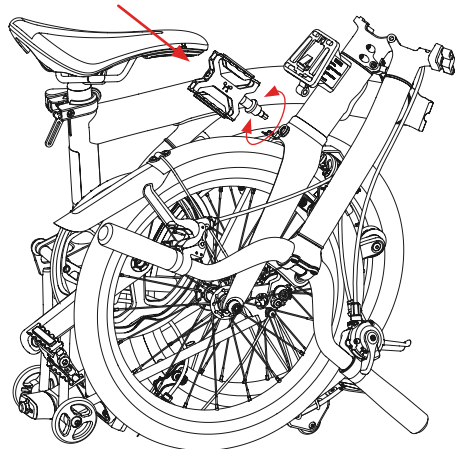

LOCKING BLOCK

ADJUSTMENT

When you pick up the folded bike, the bike cannot unfold because the locking block LB contacts the seatpost SP to stop the rear frame from moving. The LB can be adjusted to obtain the correct gap between itself and the SP. If the gap is too small the post will catch on it when folding the bike, too large and the folded bike may partially unfold when picked up.

It is easiest to make adjustments to the LB with the bike fully folded with the seatpost raised. When the seatpost is raised, make sure it is locked in place using the seat clamp.

To decrease the gap between the LB and the SP (fig. 1), using a 4mm hex key, unscrew the cap head socket screw inside the LB half a turn at a time and then lower the seatpost to check if it has clearance. If the gap is still too wide, unscrew another half turn, and check the seat post again. Repeat this process until the correct size gap is obtained.

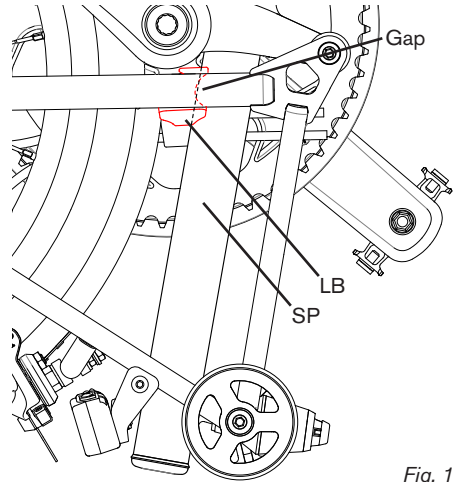

Fig. 1

PUSHING/PULLING THE BIKE WHILST FOLDED

The bike can be pushed/pulled whilst folded, as an alternative to picking up and carrying the bike. In the folded position, raise the saddle until the bottom of the seatpost comes into contact with the locking block (fig. 2). Because the locking block still contacts the seatpost, the bike is still secured in the folding position, but with the saddle slightly raised. The raised saddle can be used as a handle to push/pull the bike.

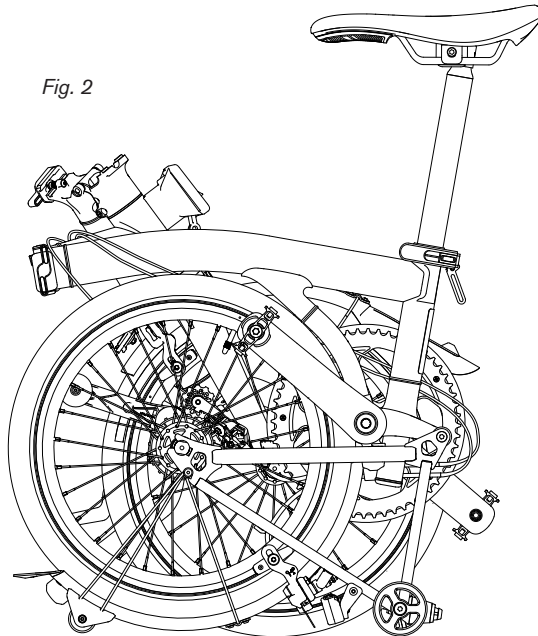

Fig. 2

USING THE BROMPTON ELECTRIC

TYRE PRESSURES

Tyre pressure is important for both comfort and safety. Please note the following tips for ensuring a safe and comfortable ride.

It is important to keep your tyres well-inflated; soft tyres increase pedalling effort (which takes the fun out of riding), wears tyres down quickly and has an adverse effect on handling. **Keeping your tyres well-inflated is highly recommended.**

The most appropriate pressure depends on your weight and preference. It's also worth remembering that a very hard tyre isn't always faster. A hard tyre might be faster in the velodrome, on a rough road a lower pressure will deflect more easily over uneven and rough road surfaces and therefore roll faster and make the ride more comfortable. Generally a slightly lower pressure in the front wheel and slightly higher in the rear is recommended, this accounts for the different weight distributions between the two tyres.

Brompton bikes are fitted with Schrader valves, allowing various methods of inflation. The Brompton pump is installed on the rear frame of all-steel Brompton Electric bikes with mudguards. When replacing the pump on the bike, make sure that it has full engagement with the pump locators on the rear frame. You can also use a hand-pump, or an air-line found at petrol/gas service stations. All Brompton Electric Bicycles use a 37 x 349mm tyre (16 x 1-3/8") and corresponding inner tube.

	MARATHON RACER		CONTINENTAL CONTACT URBAN	
	MIN(psi)	MAX(psi)	MIN(psi)	MAX(psi)
FRONT	65	110	65	116
REAR	65	110	65	116

TORQUE VALUES

A list of torque values for the major components is shown here.

These parts should be checked periodically, as well as during routine maintenance and repair of the bicycle.

If components are not tightened to the correct torque, it could cause damage or failure of the part. This could cause loss of control of the bicycle and result in a crash.

*Never try to alter the height of the handlebar stem where it enters the front forks, it should be fully inserted into the fork up to stop. If adjusting the alignment of the handlebar to the front wheel, ensure the fixing bolt is tightened correctly before riding the bike.

If the handlebar stem is not fully inserted or not tightened correctly, it could cause movement or failure of the part in use.

Part name	Torque (Nm)
Front Wheel Nuts	18
Rear Wheel Fixings	8
Brake lever bolts	2
Chain tensioner hanger nut	5
Chaining bolts	10
Crank bolts	30
Front Module	4.5
Front wheel hook and mudguard stay	2
Handle bar support expander bolt*	30
Handlebar catch clip bolt	9
Handlebar clamp bolt	18
Brake caliper nut	8
Brake (caliper) cable clamp bolt	8
Pedals	30
Pentaclip	15 (C Line), 10 (P Line)
Rear rack stay bolts	2
Mudguard Stay Fixings	2
Rear Hinge Bolt	10
Derailleur Mounting Screw	2

3-SPEED GEAR SHIFTER - RIGHT HAND SIDE

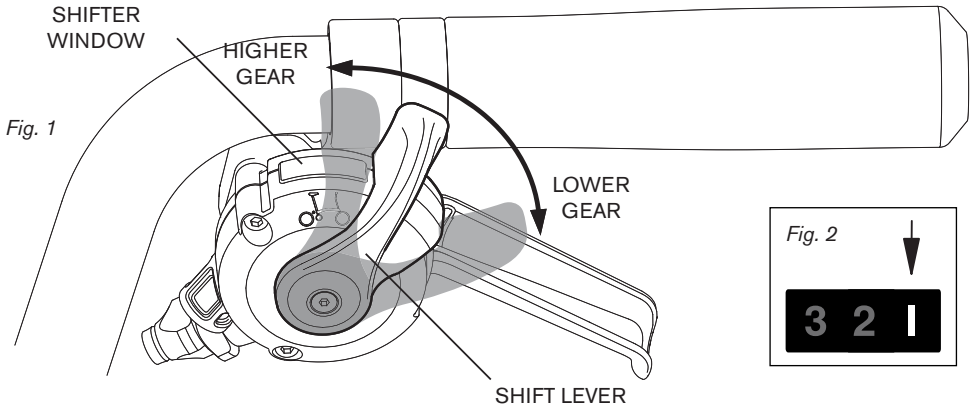

USING THE SHIFTERS

The 3-speed shifter uses a self-returning lever to change between the three gears. Pushing it down with your thumb will shift into an easier gear and flicking the lever upwards with the back of the thumb will shift into a harder gear (fig. 1, 2). It is important to stop pedalling or back pedal when changing gear, if you do not do this, it is possible to damage the hub internals. The indicator window (fig. 2) shows you which gear is selected.

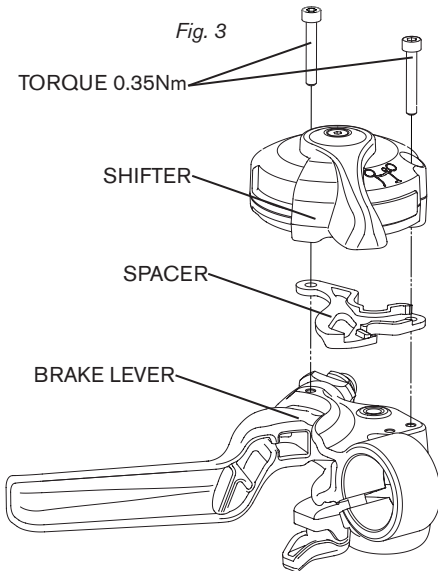

FITTING THE SHIFTERS

The shifter mounts to the right hand brake lever, it is held in place by two M3 screws, these should be tightened to **0.35Nm**. Do not overtighten the screws as this can reduce the performance of the shifter and damage the parts.

As standard, a spacer (fig. 3) is fitted between the shifter and brake lever. This spacer is vital to ensure clearance between the shift lever and the grip.

On the M, H & S-type bikes using non-standard grips, the locking collar or grip material can interfere with the lever operation, if the spacer is not fitted.

FITTING A NEW CABLE

- Select gear 1 and then press the shift lever downward so it does not obscure the cable entry hole (fig. 4)
- Feed the gear cable into the shifter and through the cable bush
- If there is resistance pushing the cable through the bush, pull the cable back a little and try again
- Once you can feel the cable pass through the bush keep feeding it until you feel slight resistance
- Keep feeding it through so that it follows around the guide inside the shifter and exits through the cable barrel

DO NOT FORCE THE CABLE AS THIS MAY DAMAGE THE SHIFTER

Fig. 4

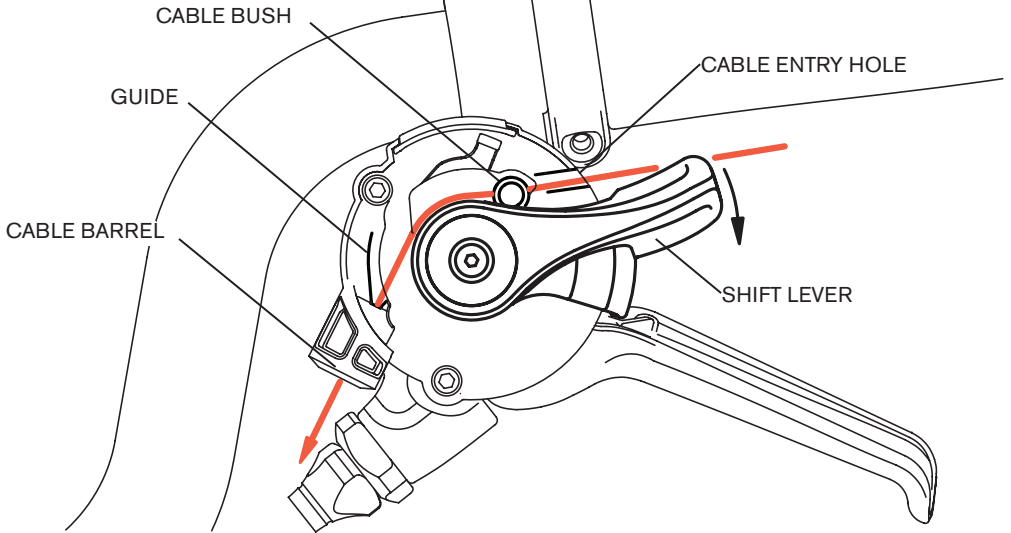

REFITTING THE GEAR CABLE

- Thread the inner cable through the cable housing
- Route the assembled cable correctly to the rear of the bike
- Thread the inner cable around the cable pulley (fig. 5)
- Thread the cable through the clamp on the cable anchor and pull through before tightening the clamp nut
- Screw the indicator chain into the gear cable anchor

HUB-GEAR ADJUSTMENT

Adjustment must be carried out with the bike fully unfolded and with the indicator rod screwed into the hub. This should be backed off no more than half a turn to align with the cable.

The aim is to make sure that the indicator rod and chain move to the correct position in response to moving the trigger.

For this the cable has to be running free of kinks or sharp bends, with the cable pulley rolling freely.

While setting gears, keep the wheel spinning forwards, and pedal back and forwards, to ensure the gear engages. It's easiest, when altering the setting, to have the cable slack: select top gear and back and forward pedal.

Adjustment is carried out by slackening the lock nut, turning the cable anchor barrel (fig. 5) to obtain correct setting, and relocking the nut.

The indicator chain is correctly adjusted (fig. 6) when the shoulder S on the indicator rod IR is proud of the axle end

by no more than 1mm (this can be seen by looking through the hole in the chain tensioner nut CTN) when in the middle position on the shifter is selected.

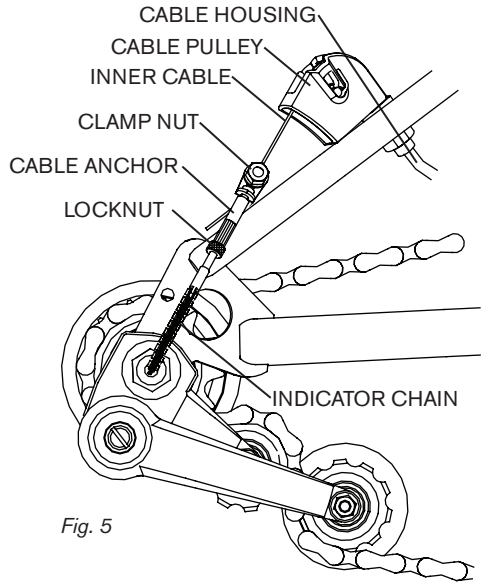

Fig. 5

REMOVING THE GEAR CABLE

- Select gear 3 on the shifter, backpedal to engage the hub
- Unscrew the indicator chain locknut (fig. 5)
- Unscrew the indicator chain from the gear cable anchor
- Undo the gear cable anchor clamp nut and release the inner gear cable
- If there is a cable crimp fitted to the cable end you will need to remove this, then pull the cable out of the clamp
- Pull the cable housing away from the shifter
- Remove the inner cable from the cable housing
- Select gear 1 and then press the shift lever downward so it does not obscure the cable entry hole
- Feed the gear cable through the shifter so that the cable nipple ejects from the cable entry hole
- If there is resistance pushing the cable through the bush pull the cable back a little and try again
- Keep feeding the cable through until the cable can be fully removed from the shifter

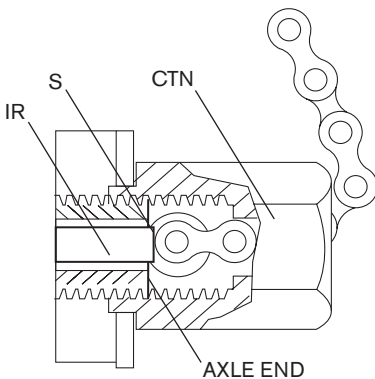
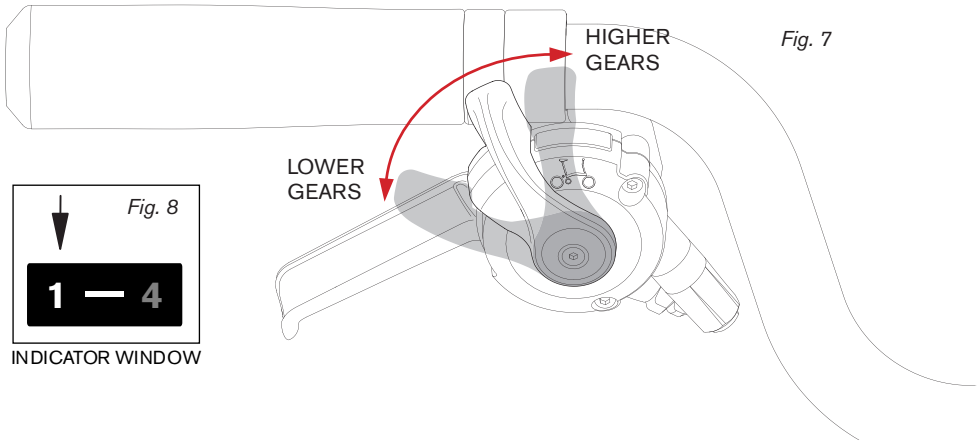

Fig. 6

4-SPEED GEAR SHIFTER - LEFT HAND SIDE



USING THE SHIFTER

The 4-speed shifter uses a self-returning lever to change between the four gears. Pushing it down with your thumb will shift into an easier gear and flicking the lever upwards will shift into a harder gear (fig.7). It is advised that each individual gear is changed while pedalling for smoother shifting or to avoid damaging the relating components. The indicator window will give an indication of which gear is selected (fig. 7,8).

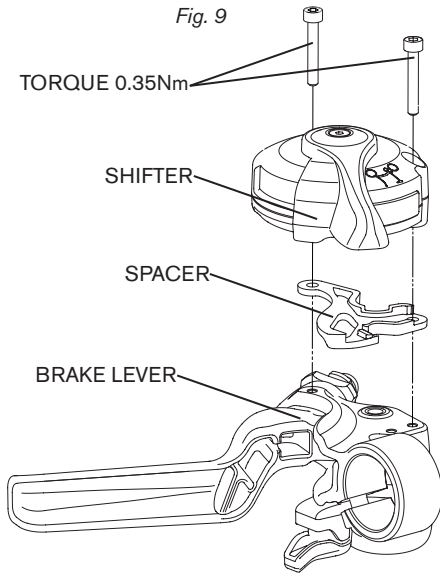

FITTING THE SHIFTERS

The shifter mounts to the right hand brake lever, it is held in place by two M3 screws, these should be tightened to **0.35Nm**. Do not over tighten the screws as this can reduce the performance of the shifter and damage the parts.

As standard a spacer (fig. 9) is fitted between the shifter and brake lever. This spacer is vital to ensure clearance between the shift lever and the grip.

On the M, H & S-type bikes using non-standard grips, the locking collar or grip material can interfere with the lever operation, if the spacer is not fitted.

FITTING A NEW CABLE

- Screw the barrel adjuster fully clockwise so that it is at its shortest setting, then unscrew by 2 turns
- Select the lowest gear (1) and then press the shift lever downward so it does not obscure the cable entry hole
- Feed the gear cable into the shifter in a slightly downward direction and through the cable bush
- If there is resistance pushing the cable through the bush pull the cable back a little and try again
- Once you can feel the cable pass through the bush keep feeding it until you feel slight resistance
- Keep feeding it through so that it follows around the guide inside the shifter and exits through the barrel adjuster.

DO NOT FORCE THE CABLE AS THIS MAY DAMAGE THE SHIFTER

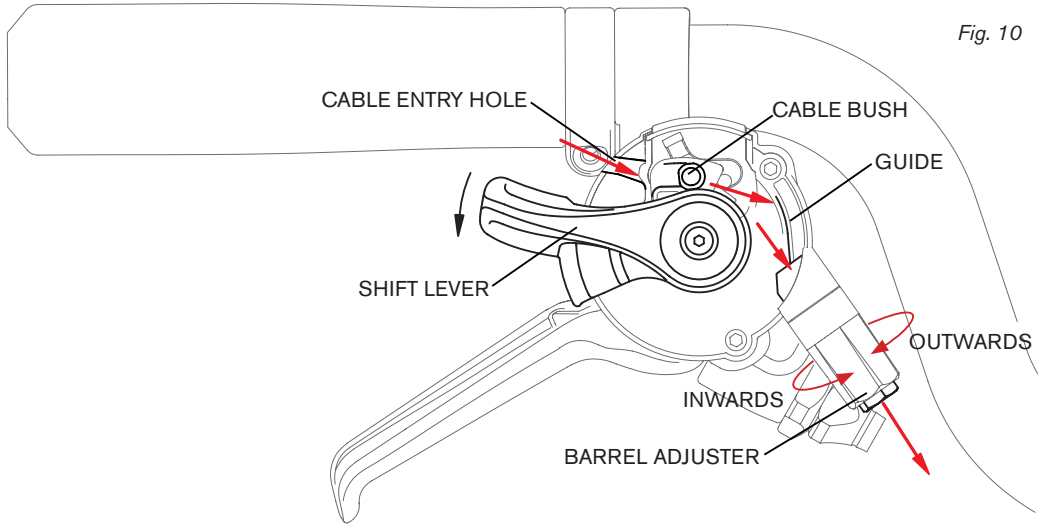

SETTING THE GEARS

- Insert the inner cable IC into the cable housing CH (fig.12)
- Thread it all the way through until it exits through the end of the housing
- Route the cable along the bike frame following the same paths as the existing cables. This is essential for folding
- When the cable reaches the rear frame, route the cable through the stopping block SB (fig. 11)
- Using some needle nose pliers or similar, pull the cable through the housing and insert into the derailleur (fig.12)
- Tighten the bolt RS that holds the cable in place on the inside of the derailleur (fig. 13)
- Use the barrel adjuster on the shifter to make adjustments to the cable tension as needed (fig. 10)
- Unscrewing the adjuster will add more tension to the cable and improve shifting into the lower gear
- Screwing the adjuster inwards will reduce tension and improve shifting into the high gear (**See gear adjustment information below**)
- The jockey wheel on the derailleur needs to be in-line with the selected gear sprocket on the cassette

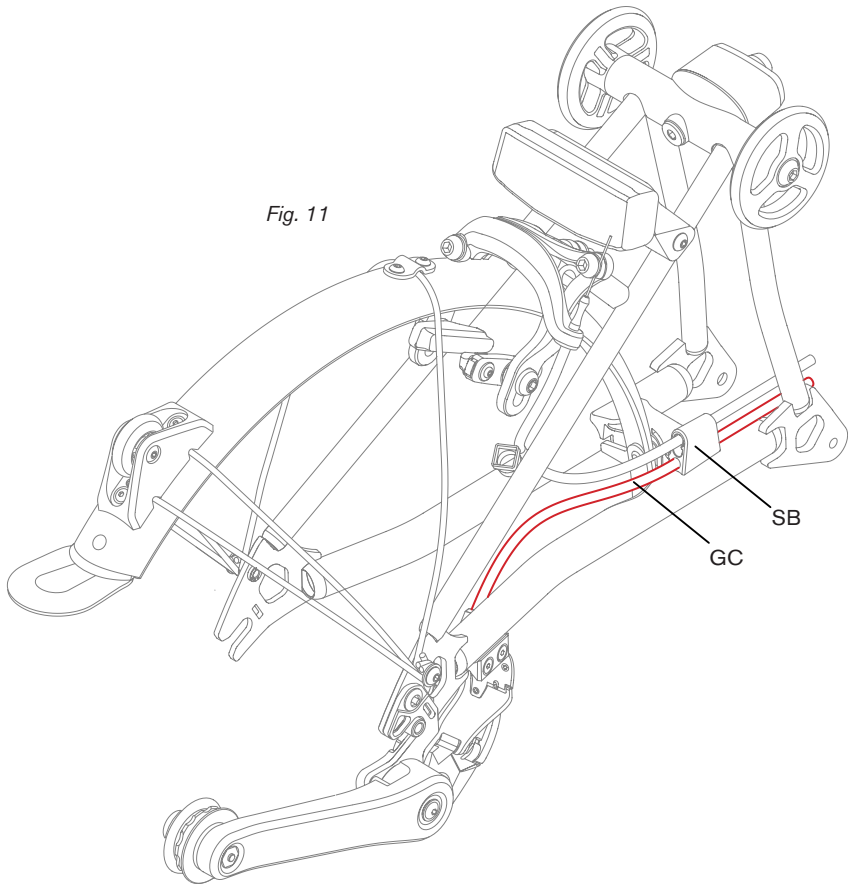

ADJUSTMENT

If the gears become louder than normal or start to skip and this is not due to dirt and grime on the parts, it could be due to cable stretch. This is especially common for new bikes or where new cables have been fitted. This can be fixed by adding tension to the cable, **See cable tension instruction below.** The derailleur not being aligned properly could also cause the same issue though this usually affects the highest and the lowest gear. In which case you will need to adjust the two limit screws LS on the outside of the derailleur. **See limit screws instruction below.**

Fig. 12

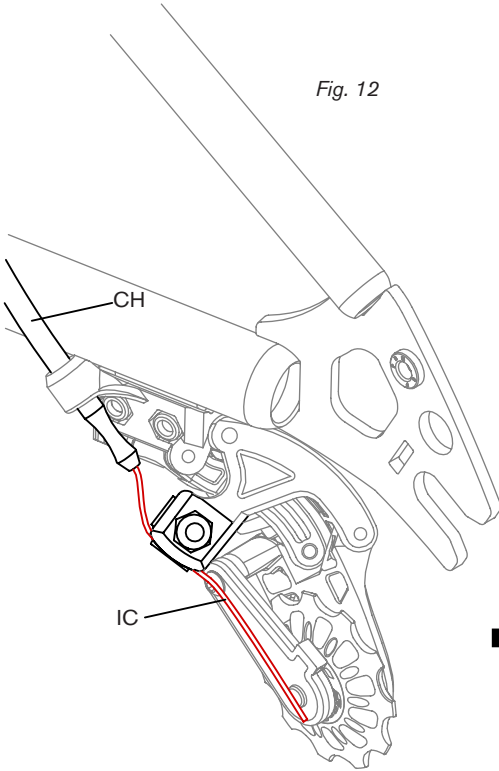
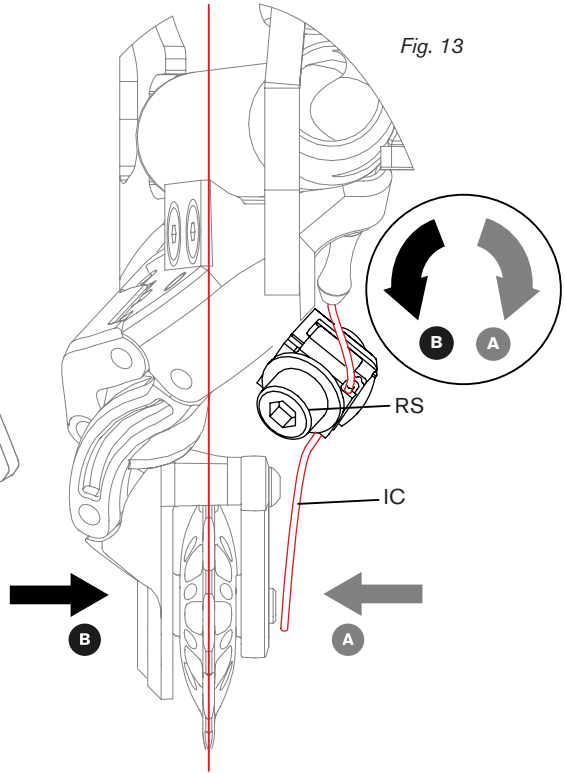

Fig. 13



LIMIT SCREWS - The limit screws LS operates in the same way they would on the traditional gearing system. These are used to set the limits on how far inwards or outwards the derailleur can carry the chain. If there is an issue with reaching the highest or the lowest gear, the limit screw may need adjusting. 2mm hex key is needed for adjusting.

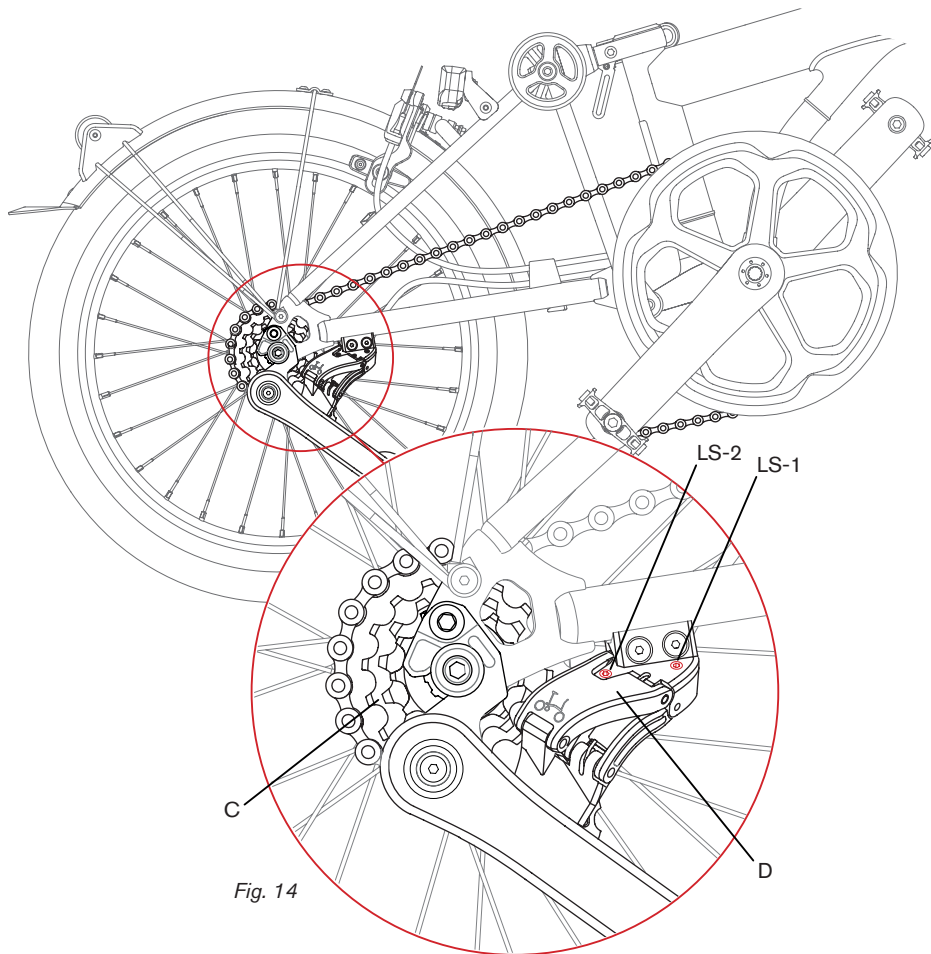

Fig. 14

LS-1 is used to create alignment on the largest sprocket on the cassette. **LS-2** for the smallest (fig. 14).

CABLE TENSION

To add tension lost due to cable stretch, place the bike in a stand. Unscrew the barrel adjuster (fig. 7) outwards a quarter turn at a time, each time pedalling the bike whilst listening for the reduction of noise. A visual check can also be done to insure that the jockey wheel on the derailleur is aligned with the selected sprocket on the cassette. If the bike is failing to reach the largest sprocket this means that too much tension have been added screw the barrel adjuster inwards to remedy this issue (fig. 10).

MAINTAINANCE

It is vital that the key functional components like the chain, cassette and derailleur are kept clean and chain lubricated. These components should be checked periodically for damage and replaced whenever necessary. If these components are kept clean their lifespan will be extended and they will function better. If there is a build up of grease and dirt on the drivetrain, the gearing may not work properly.

BRAKES

You should adjust your brakes on a regular basis as they are critical to your safety. The time between adjustments will vary depending on how often you use your Brompton; if your brake lever touches the handle bar when you pull on it, your brakes need urgent adjustment. The brakes should be set so that the brake pads are as close to the rims as possible without interfering with the rotation of the wheels. Adjustment is carried out using the threaded cable stop on the brake lever. If you are unsure of how to do this, have it adjusted by a Brompton dealer or qualified bicycle technician.

- When setting the rear brake, the bicycle should be unfolded
- When setting the front brake, do not set the pads so close that they bind on the rim when the wheel is turned to the right or left
- Replace your brake pads if the grooves on the brake pad surface are less than 1mm deep

Keeping your rims and brake pads clean will improve your braking performance and increase the lifespan of the pads and rims. The black residue that accumulates on the rims is a mixture of dirt, pad material and aluminium powder worn from the braking surface of the rim, this residue is abrasive and will accelerate the wear of the rim and pads. When cleaning the pads and rims check to ensure they are not worn out and a worn rim or pads should be replaced immediately.

BRAKE LEVER ADJUSTMENT

In order to achieve a comfortable and safe brake lever position, it is important to spend some time ensuring the lever is correctly adjusted. Depending on your hand size, you can adjust the distance of the lever from the bar; the lever can be set to be operated by one, two or three fingers.

The left and right hand levers are specifically designed for their respective positions; the lever is fitted with the clamp bolt facing upwards (fig. 22).

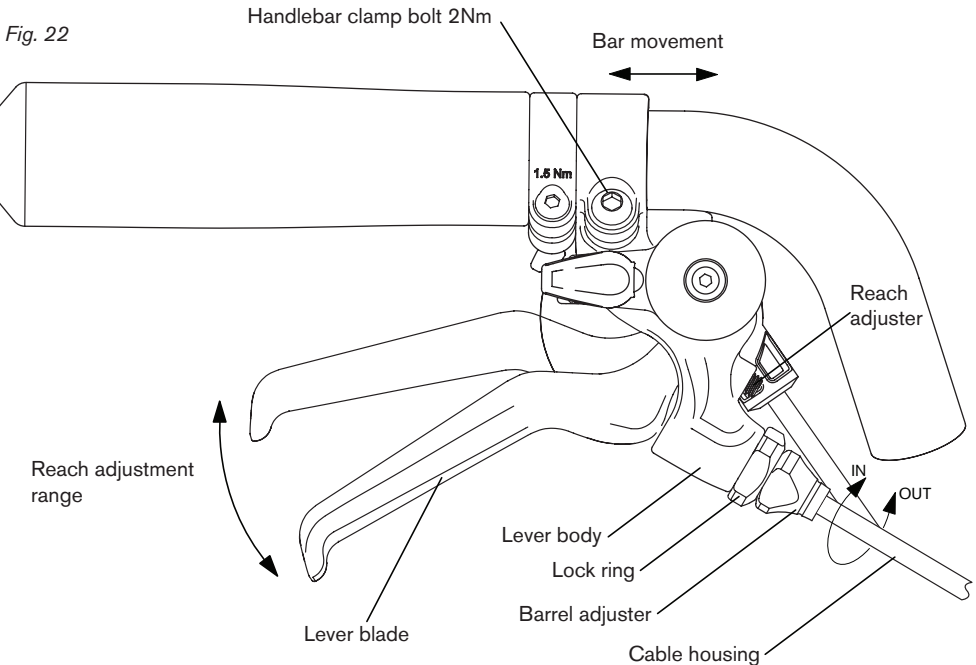

1. LEVER ANGLE

The range of lever angle adjustment is restricted by the cable exit path, if the lever is angled too high it will cause problems for the operation of the brakes and in folding the bike.

When the bike is folded, the right hand brake cable housing will contact the fork leg. The lever angle should be set so that the cable housing lightly contacts the fork leg; too much contact will bend and damage the housing. For this reason, the lever blade features a kink allowing the lever blade to sit higher than the lever body, this offers a more comfortable position without affecting the cable housing path.

2. LEVER POSITION

The position of the lever on the bar can be adjusted to move the lever closer or further from the end of the handlebar grip. This adjustment will allow the lever to be positioned for one, two or three finger braking.

Positioning the lever for one finger braking will give a more secure grip on the bar but allow you to apply less braking force. Three finger braking will allow you to apply maximum braking force but reduce bar grip.

3. REACH ADJUSTER

Lever reach adjustment is controlled by the grub screw on the side of the lever body.

Screwing the reach adjuster into the lever body (2.5mm hex key) will bring the lever closer to the handlebar.

When the lever reach is adjusted closer to the handlebar it will cause the brake pads to move closer to the wheel rim. It may be necessary to adjust the lever bite point (engagement position) in order to give sufficient pad clearance; this can be achieved by screwing the barrel adjuster into the lever body.

If there is not enough adjustment at the barrel adjuster to give sufficient pad clearance and a satisfactory lever bite point, you may need to loosen the cable clamp bolt (10mm spanner) at the brake caliper to allow some cable to be pulled through. Be sure to re-tighten this bolt to 8Nm and ensure the cable is properly secured before using the bike.

4. BITE-POINT ADJUSTMENT

Lever bite-point (engagement position) adjustment is controlled by the barrel adjuster. Screwing the barrel adjuster into the lever body will bring the lever bite-point closer to the handlebar. Screwing the barrel adjuster outward from the lever body will move the bite point further from the handlebar.

The barrel adjuster uses a lock ring to secure it in position; this should be loosened before adjustment and tightened once the barrel adjuster is correctly positioned.

5. SECURING THE LEVER

Once the lever has been correctly positioned on the bar, the clamp bolt should be tightened to a torque of 2Nm (4mm hex key).

Correct cable routing and cable housing length is essential; cables must pass in front of the handlebar, to the left of the handlebar support and to the right of the main frame tube.

IF YOU ARE UNSURE ABOUT ANY OF THESE ADJUSTMENTS CONSULT YOUR BROMPTON DEALER, DO NOT ATTEMPT TO USE THE BIKE WITH POORLY ADJUSTED BRAKES

Fig. 23

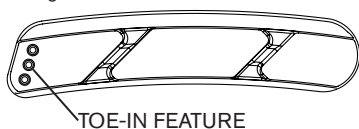

BRAKE PAD SETUP

The brake pads have a toe-in feature (fig. 23) which consists of three raised points on the rear end of the braking surface. This helps angle the pad slightly when setting it up (fig. 24) to 'toe-in' the pad and reduce vibration and noise when braking.

If you need to replace worn pads, ensure you use genuine Brompton replacement brake pads, designated for use with the Brompton Electric.

Fig. 24

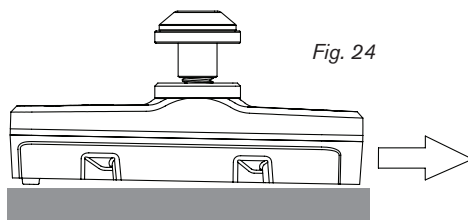

When the brake caliper has been fitted and secured, you can set the position of the brake pads. Ensure that the surface of the brake pad is aligned with the curvature of the rim (fig. 25) and is just above the bottom edge of the braking surface on the rim. Once the pads are correctly positioned they should be tightened to 5Nm.

Fig. 25

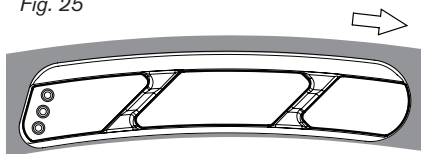

LIGHTING

A Lighting system is available for the Brompton Electric; a front and rear lamp, powered by the battery. These can be added to bikes not originally equipped with a lighting system, this work can be carried out by an authorised Brompton Electric Dealer. Please use these lights in accordance with local laws. For information relating to the operation of the lighting system please refer to page 16.

THE REAR FRAME CLIP

To release the rear frame press the small lever (fig. 26) forward and lift the bike so the suspension block moves away from the latch and the rear wheel swings under the frame. Lower the bike so it sits in the parked position.

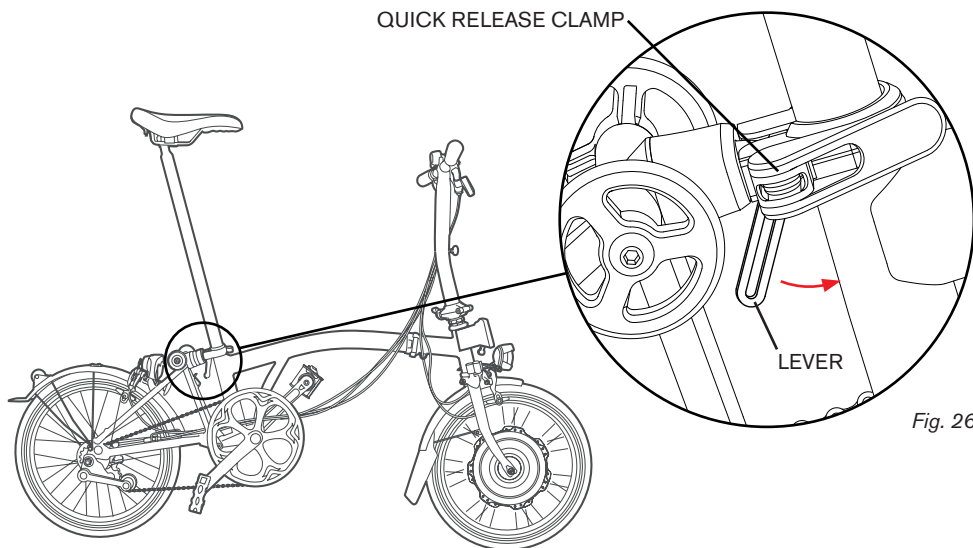

Fig. 26

SEAT CLAMP QUICK RELEASE ADJUSTMENT

The quick release clamp should be adjusted so that the lever (fig. 26) closes firmly. If the movement is easy, with no resistance, the seatpost will not be properly secured. With the seat clamp lever closed, the adjuster nut on the opposite side of the clamp band should be tightened to 4-7Nm. When correctly set, there should be no slippage of the saddle and it should not move when riding or carrying the bike. Minor adjustments of the clamp may be needed from time to time.

Do not overtighten the nut, as this can cause damage to the frame.

If the post still slips when properly adjusted, this could be caused by contamination, with oil or grease. Remove the seatpost from the bike, and clean the post and the plastic sleeve in the mainframe with degreaser. The plastic sleeve inside the frame will wear over time and may eventually need replacing; this can be carried out by your Brompton electric dealer.

FRONT LUGGAGE CARRIER & BATTERY CONNECTOR

Brompton has a selection of front luggage compatible with the Brompton Electric. Standard front luggage is not compatible with the Brompton Electric. The front luggage capacity of the Brompton Electric is 6.2kg and the bag and battery weigh upto 3.8kg; giving a maximum total load of 10kg. The capacity of the rear rack (R-Version bikes only) is 10kg. Ensure that when carrying luggage you do not exceed the maximum load for the bicycle (including luggage, battery and rider) of 110kg. Using incorrect luggage may interfere with steering and could be dangerous.

- Do not attempt to remove or modify the block from the bike
- If you have any problems with the front carrier block or battery connection, stop using the bike immediately and contact your Brompton Electric dealer
- Check that there is no play in the front carrier clock relative to the bike frame before each ride
- When the front luggage is loaded, the steering and braking may behave differently
- The Brompton Electric luggage is compatible with all handlebar configurations
- Do not attempt to use the Brompton Electric luggage, or Brompton Electric front carrier with any other bicycle

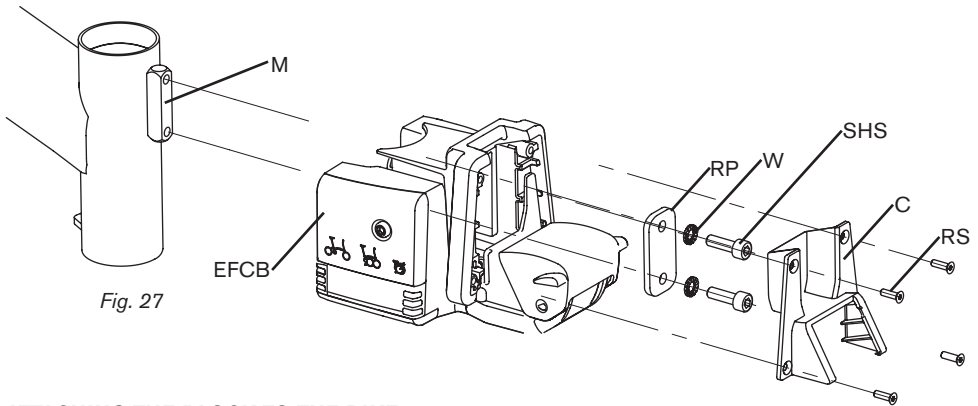

ATTACHING THE BLOCK TO THE BIKE

- The luggage mounting block EFCB (fig. 27) is pre installed on every Brompton Electric bike and should not need adjusting, it should not be removed or modified
- If the block becomes loose you should stop using the bike and have it inspected by an authorised Brompton Electric dealer
- When the block is secured to the bike it is vital to not omit either of the serrated washers W when fitting the retaining plate RP and that the correct torque is used on the screws SHS
- The blue patch on the screw is there to lock the screws in place; do not tamper with, remove or expose this patch to moisture as the locking action will be greatly reduced
- The screws should not be re-fitted after the initial instillation; the blue patch will not function correctly
- The screws should be replaced with Brompton part QFCB-BOLTS or two M5x16 socket head cap screw, Class 12.9 DIN 912 with medium strength threadlock applied to the threads before instillation

In order to tighten the mounting screws SHS (fig. 27), remove the cover C by unscrewing the 4 retaining screws RS. Assemble the retaining plate RP and one of the new M5 socket head screws SHS, together with its star-washer W into the body of the carrier block FCB. Address this to the head tube on the bicycle the correct way up as shown.

- Insert the first screw by two to three turns, do not tighten fully
- Insert and do up the second screw with serrated washer W
- Finally tighten both screws to a Torque of 4.5Nm
- Refit the cover C
- Carefully tighten the 4 retaining screws RS to 0.5Nm

REAR RACK

The rear rack has a load capacity of 10kg. It mounts to the rear frame in four points, the axle plates (fig. 28) and the mounts on the seatstay, below the rollers. The rear mudguard mounts to the rear reflector mount (fig. 29) and brake bolt (fig. 30).

Before fitting it is worth removing the rear wheel from the bike in order to make it easier to fit or remove the rack, information on this can be found on page 43.

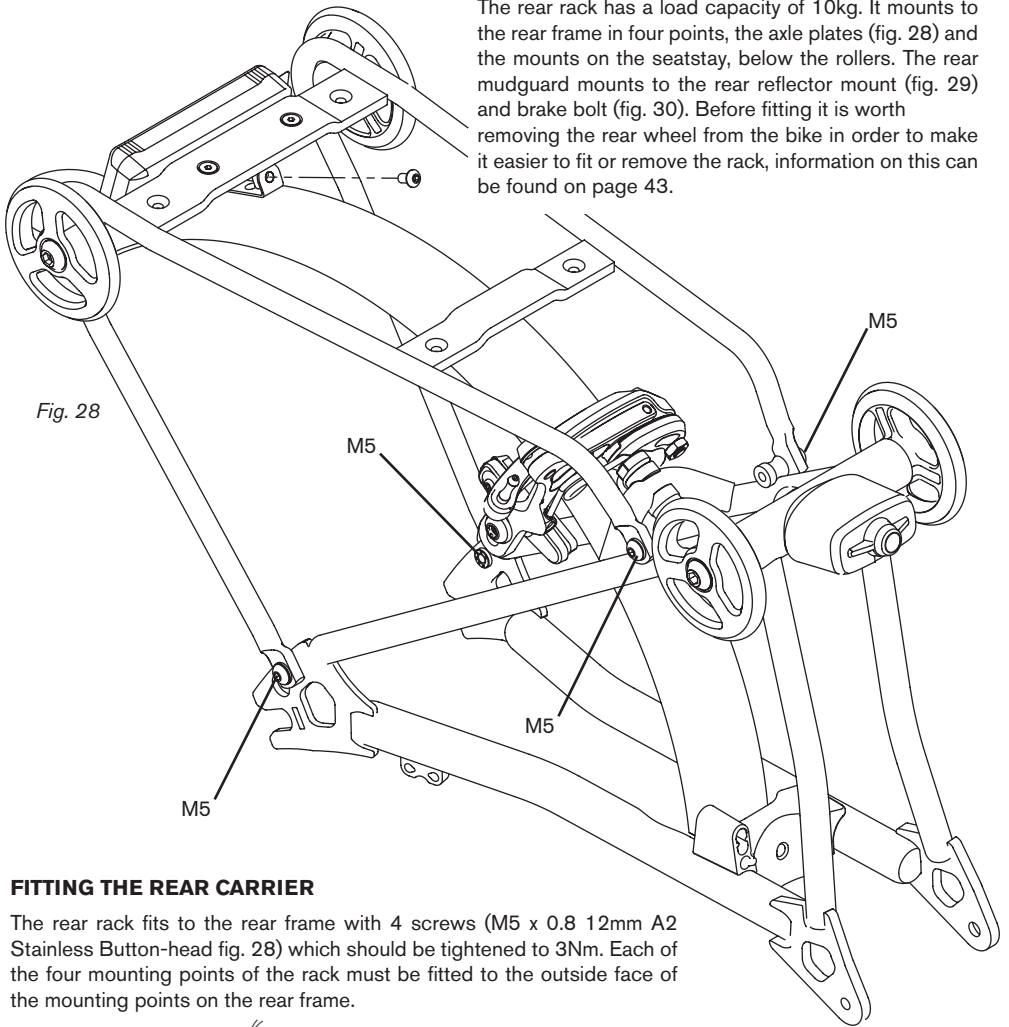

FITTING THE REAR CARRIER

The rear rack fits to the rear frame with 4 screws (M5 x 0.8 12mm A2 Stainless Button-head fig. 28) which should be tightened to 3Nm. Each of the four mounting points of the rack must be fitted to the outside face of the mounting points on the rear frame.

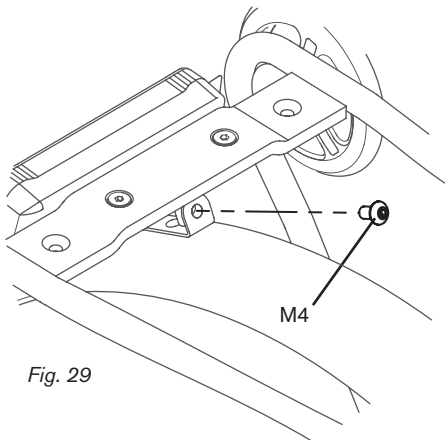

MUDGUARD REAR MOUNTING POINT

The mudguard mounts at two positions, the forward mount at the brake (fig. 30), as well as another mounting point at the rear of the rack (fig. 29) where the rear reflector/light mount is.

The mudguard should be attached to the lamp bracket (fig. 29) point by an M4x1mm A2 stainless button head screw, tightened to 1.5Nm. Take care when tightening the screw to ensure the mudguard does not twist and stays aligned with the rack.

MUDGUARD FORWARD MOUNTING POINT

The mudguard should be attached to the brake bolt (fig. 30) point by an M6 Nut and washer, tightened to 2Nm. You should not need to remove or adjust the brake or brake fixing nut to mount the mudguard, take care when tightening the mudguard fixing nut, not to move the brake caliper.

WARNING

The maximum load of the front carrier block is 10kg, the maximum load of the rear rack is 10kg. Do not exceed the maximum load for the front and rear luggage or modify the rear rack, front carrier block or front luggage frame. The fixings of the front carrier block and rear rack should be checked regularly. The front carrier block and rear rack are not suitable for mounting of a child seat. Do not attempt to carry luggage anywhere else on the bicycle. The bike and rear rack are not designed to pull a trailer.

When the luggage carriers are loaded the bicycle may behave differently, steering and braking may be affected. Luggage should be loaded evenly.

Before riding ensure that the front bag, front carrier block, rear rack and rear bag are secure and there are no loose straps or items of luggage that could get caught in the wheels of the bicycle. Ensure that any luggage fitted does not obscure the reflectors and any lighting fitted to the bike.

The Brompton front carrier block, carrier frames, front luggage, rear rack and rear luggage are only compatible with Brompton bikes. Only luggage carriers and luggage manufactured or distributed by Brompton Bicycle Ltd should be used with the Brompton bike.

CLEANING & LUBRICATION

It is important to lubricate components to keep them running safely and efficiently. We recommend you do this regularly, though some parts will need more frequent lubrication. The chain has to be well-lubricated for smooth pedalling. Apply chain lubricant while turning the pedals backwards, making sure it flows onto the rollers; allow the oil to work in by continuing to turn the pedals backwards, then wipe off any excess.

When lubricating the chain its worth remembering that you are trying to lubricate the chain rollers and not the plates, any lubricant on the plates isn't going to aid drivetrain efficiency and will simply serve to attract dirt. The best method is to carefully apply one drop of lubricant to each roller, this will take a little longer than just squirting lube on the chain while you back pedal, but will ensure the lube gets where it's needed and nowhere else.

The thread of the hinge clamp bolt and its washer should be greased occasionally. A thin smear of grease on the inside faces of the clamp plates also help them release more easily. The gears and bearings are sealed; greasing need only be carried out during a major service by a bicycle mechanic.

When lubricating your Brompton, avoid getting oil or grease on the seatpost or the wheel rims. Any good quality general purpose grease is satisfactory. For the chain, 'dry' chain lubricants with good penetrating properties give the best results. Consider the environmental impact of the lubricants and greases you use.

WARNING

Remove the battery before cleaning & maintenance of the bike. Do not use a jetwash or hose to clean the bike or the battery. This can force water into the motor, battery and electrical components; damaging them and causing them to function incorrectly. Do not use solvents, aerosol cleaners or degreasers to clean the bike. For best results clean the bike with warm soapy water and a sponge. Keep the battery dry, wipe the battery down with a dry cloth to clean it.

Continued on next page

Fig. 30

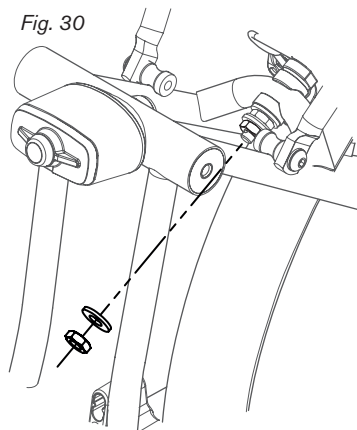

Do not submerge the bike, hub motor or battery in water; this can allow water to enter the motor, battery and electrical systems. This could cause overheating bursting or ignition. Do not place the battery or bag down on a wet floor, this could allow water onto the battery connector. Do not use the bike if it has been submerged in water. Only clean the bike when upright and unfolded, do not clean the bike when upside down.

CLEANING THE BATTERY CONNECTION

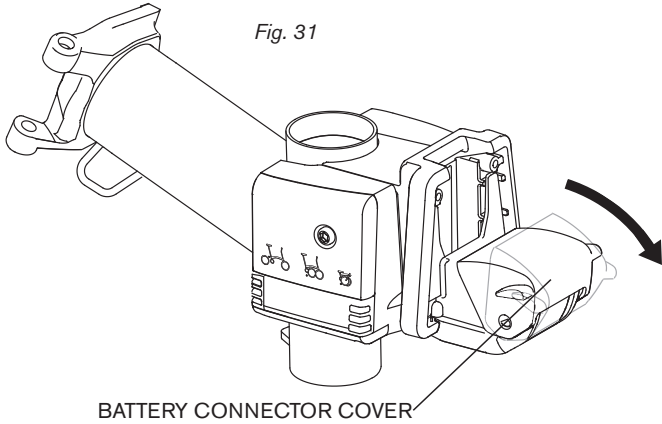

The battery connector on the front mounting block is protected by a cover (fig. 31) to prevent contamination from the elements, when the battery/bag is not fitted to the bike. It is still possible for contaminants to get under the cover and they could prevent the battery connector from functioning correctly.

It is recommended to regularly clean the battery connector. Push the cover forward to open it (fig. 31) and using a dry, lint free cloth to wipe away any contaminants.

You should also check and clean the battery connector on the base of the battery (fig. 32), with a clean, dry, lint free cloth.

Do not use contact-spray, detergents or lubricants on the battery connectors.

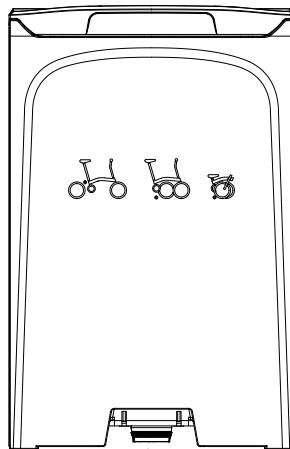

Fig. 32

ADJUSTING THE SADDLE POSITION

The angle and fore-aft position of the saddle can both be adjusted. To establish the most comfortable position you should start by adjusting the saddle into a neutral position; you can then work from there to find the best position. First loosen the Pentaclip bolt using a 5mm hex key until the saddle can be moved with little force. Be careful not to loosen this bolt too much as this will make adjustment more difficult.

Move the saddle rails in the clamp so that they are roughly centred (half way between maximum fore and aft position). Adjust the saddle into a level position, so that the top surface of the saddle is roughly level between the front and rear edge (fig. 35). Once the saddle is in a neutral position, tighten the Pentaclip bolt to 15Nm (C Line) / 10Nm (P Line). Test the saddle position, you can adjust it to make it more comfortable.

ANGLE

If the nose feels like its pointing up, or feels as though the back of the saddle isn't giving enough support, you can angle the saddle forward. The saddle could conversely feel like it needs tilting back a little, to give more support from the nose, or if it feels like all the riders weight is resting on the back of the saddle. Once you have adjusted the saddle, tighten the Pentaclip bolt and spend some time riding, readjusting if necessary.

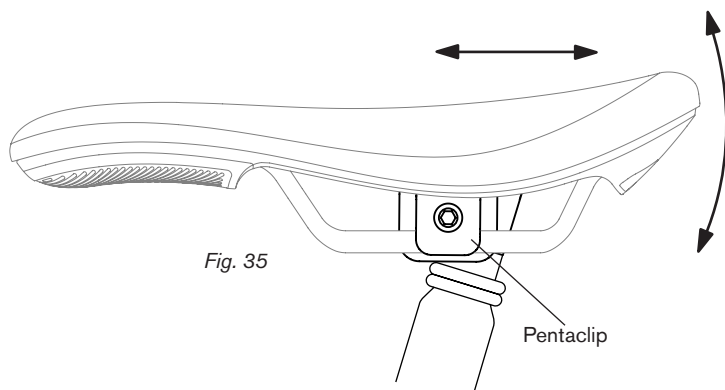

FORE-AFT POSITION

Moving the saddle back and forth from the neutral middle position will not only affect the reach (to the handlebar) but also the position relative to the pedals. By moving the saddle back you will increase the reach to the bars and make the bike a little more stretched out. Moving the saddle forward will make the bike feel shorter and more upright. Test the bike and readjust if necessary, making sure you securely tighten the Pentaclip to 15Nm (C Line) / 10Nm (P Line).

ADDITIONAL SADDLE HEIGHT

If you can't gain enough height by re-positioning the saddle, there are two Brompton options which give more height: a telescopic seat pillar and a longer pillar extended by 60mm. The telescopic pillar can accommodate the needs of taller riders, with little change to the folded size.

The handlebars and control levers on the Brompton are factory-set to provide a compromise between compactness and riding comfort. Should you choose to make any changes, the folded handlebar or stem cannot lie as close to the front wheel as normal and increases the folded package.

If the handlebar stem assembly has to be moved for any reason, it is highly recommended that any adjustments are made by an authorised Brompton dealer or certified bicycle technician. The clamp bolt should be tightened to a torque of 15Nm (C Line) / 10Nm (P Line).

SADDLE HEIGHT INSERT FITTING

Once you have the correct saddle position you can fit the saddle height insert. This should be fitted in cases where the saddle height is too high at maximum extension. The saddle height insert will allow you to set the saddle at the correct height each time the bike is unfolded.

SETTING THE SADDLE HEIGHT

- Remember to use your usual cycling shoes at this stage
- Adjust the saddle height so that when the pedal is at the bottom of the stroke and the heel of the shoe is on the pedal, your leg is straight (fig. 36)
- When pedalling with the front of the foot, your leg will be slightly bent at maximum extension
- Once you are happy with the saddle height, mark the seatpost with a marker pen or tape at the top of the seat-slide tube (fig. 37)
- The minimum height of the seatpost is reached when the seatpost extends out of the seat tube, below the bottom of the frame; the bike should not be ridden with the seatpost protruding from the bottom of the seat tube
- If you are unsure about the fitting process, your Brompton dealer will be able to assist you

Fig. 36

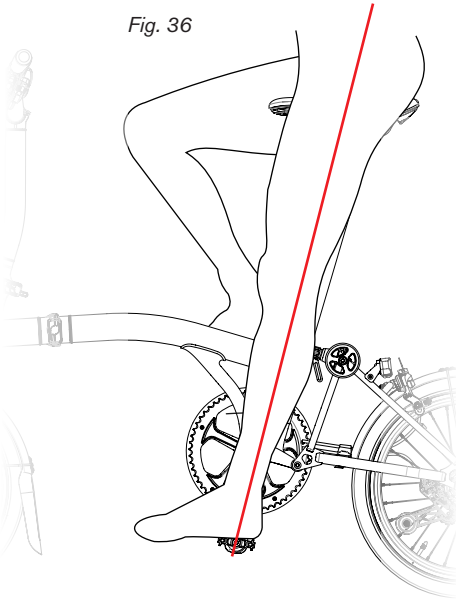
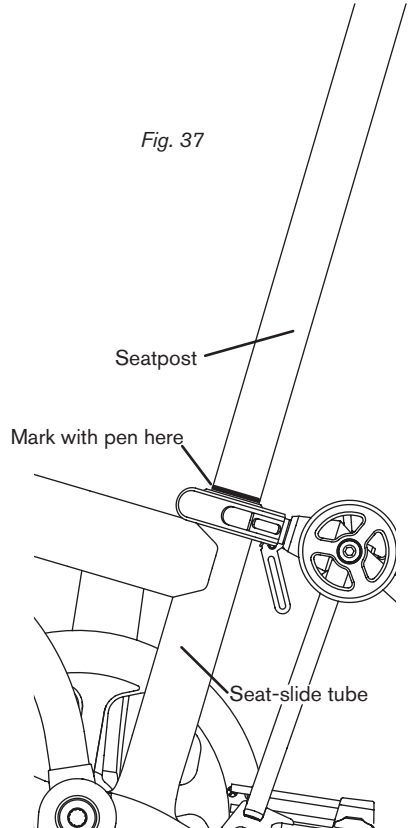
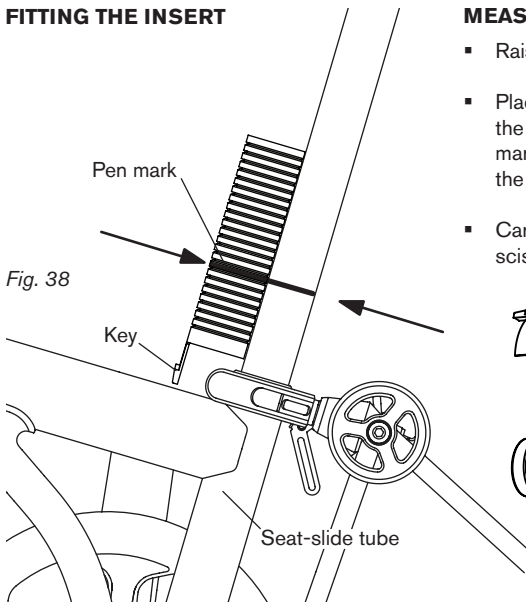

Fig. 37



FITTING THE INSERT



MEASURING AND CUTTING THE INSERT

- Raise the seatpost to maximum height
- Place the insert upside down against the post at the top of the seat-slide tube as shown (fig. 38) and mark the groove in the insert, closest to the mark on the seatpost
- Carefully cut the insert along this groove with scissors (fig. 39)

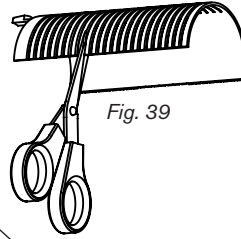

- Mark the Pentaclip to show the saddle angle and position on the Pentaclip using a marker pen or tape
- Loosen the Pentaclip with a 5mm hex key and remove the saddle and O-rings from the top of the seatpost
- Remove the seatpost by sliding it out from the underside of the frame
- Squeeze the saddle height insert and insert it into the top of the seat-tube, aligning the key with the slot (fig. 40)
- Engage the key with the base of the slot (fig. 40)
- Refit the seatpost into the underside of the frame (fig. 40), making sure the post is clean
- Refit the O-rings and saddle, align the setting marks on the Pentaclip and tighten to 15Nm (C Line) / 10Nm (P Line)
- Check the saddle height is correct at full extension, small adjustments can be made by moving the Pentaclip position up or down slightly on the post (fig. 35), for more information see <https://www.brompton.com>

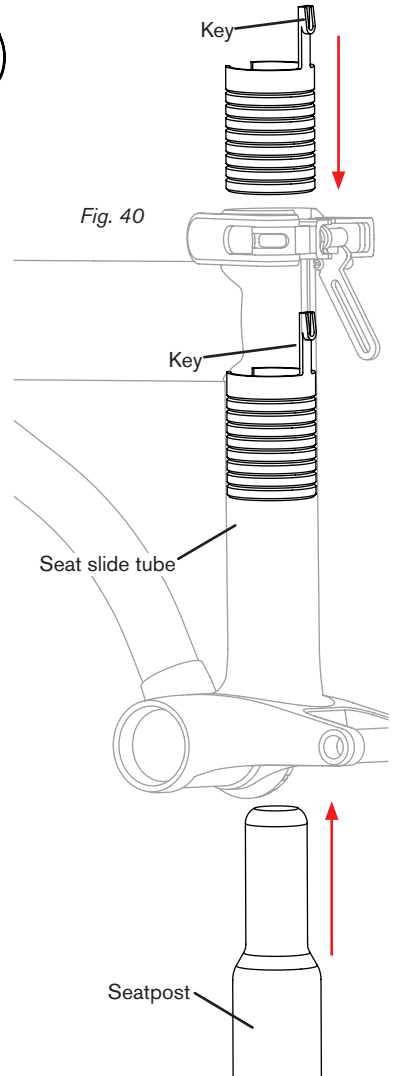

REAR WHEEL – REMOVAL AND REFITTING

- When fitting or removing the rear wheel, change the gear to the small sprocket on the cassette
- The chain tensioner should be disengaged from the chain before removing the wheel
- When fitted, ensure the wheel is seated correctly in the dropout, if not the gears may not function properly
- It is vital that you follow the correct fitting procedure and tighten all fixings correctly

Fig. 41

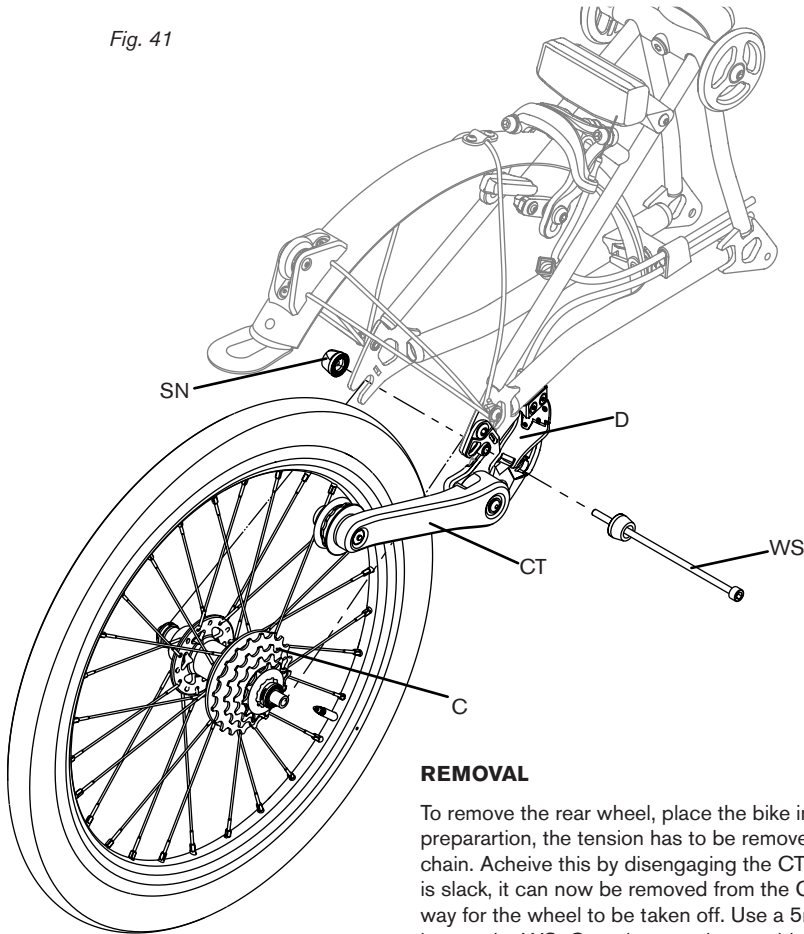

REMOVAL

To remove the rear wheel, place the bike in a stand. In preparation, the tension has to be removed from the chain. Achieve this by disengaging the CT. Once the chain is slack, it can now be removed from the C, and out of the way for the wheel to be taken off. Use a 5mm hex key to loosen the WS. Once loosened, to avoid the skewer nut SN spinning on the opposite side, hold it in place. Then completely remove the WS. For the wheel to pass the brake caliper, the tyre has to be deflated. The wheel can now be guided out with little pressure.

FITTING

When fitting the rear wheel, place the bike in a stand. Ensure that the correct running orientation by checking that the arrow on the tyre wall is indicating a forward running orientation. Guide the wheel in place ensuring that the chain can be correctly seated on the cassette C later. Once the wheel is seated in place. Insert the skewer WS as shown (fig. 41). Tighten the skewer bolt to 8Nm. The chain tensioner CT can now be engaged by the chain.

REAR WHEEL – 12-SPEED REMOVAL AND REFITTING

- When fitting or removing the rear wheel, change the gear to the small sprocket on the cassette
- The chain tensioner should be disengaged when removing the rear wheel
- Ensure the wheel is seated correctly in the dropout, if not the gears may not function properly
- It is vital that you follow the correct fitting procedure and tighten all fixings correctly

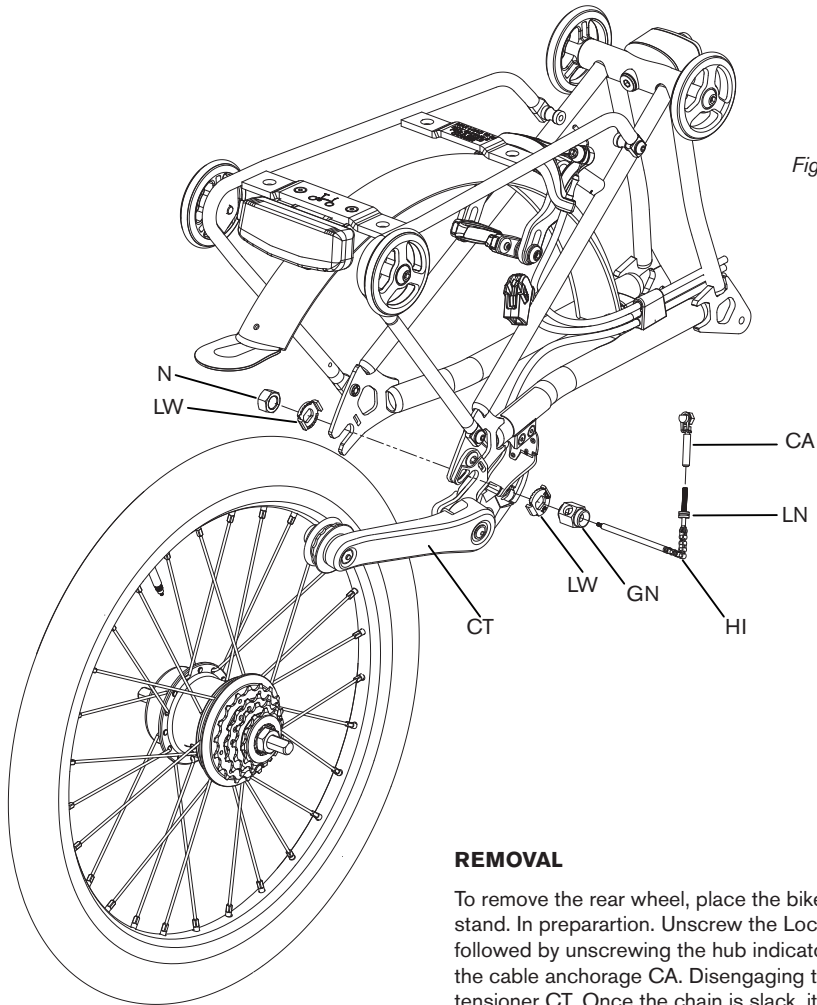

Fig. 1

FITTING

When fitting the rear wheel, place the bike in a stand. Guide the wheel in place ensuring that the chain can be correctly seated on the cassette later. Once the wheel is seated in place, fit the locking washers LW on both sides as shown, (fig. 1). Fit the nut N and the guide nut GN and tighten to 8Nm.

Consult Page 16 for removing/installing the gear cable, and hub gear adjustments.

REMOVAL

To remove the rear wheel, place the bike in a stand. In preparation. Unscrew the Lock nut LN, followed by unscrewing the hub indicator HI from the cable anchorage CA. Disengaging the chain tensioner CT. Once the chain is slack, it can now be moved out of the way. Use a 15mm spanner to loosen the nut N and the guide nut GN. For the wheel to pass the brake caliper, the tyre must be deflated. The wheel can now be guided out.

FRONT WHEEL – REMOVAL AND REFITTING

When removing the front wheel it is easiest to do with the bike in a workstand to lift it from the floor, or with the bike in the parked position so that the bike can support itself. If the tyre is deflated it can pass through the brake pads more easily. Remove the battery and luggage from the bike before working on the bike.

DISCONNECTING THE MOTOR CABLE

The cable connector is located next to the left hand leg of the fork above the hub motor (fig. 42). Unscrew the bottom section of the metal threaded connector (fig. 43) fully, by turning it clockwise (viewed from the rear with the bike upright) then gently pull the two halves of the connector apart. The upper half can remain attached to the fork; the lower half should be moved downwards in a clockwise direction and unclipped from the plastic hook.

REMOVING THE WHEEL

Slacken the wheel nuts by few turns using a 15mm spanner, enough to allow the tab-washer to disengage from the fork dropout. If the axle or tab-washer tends to stick in the slots, push the rim from side to side to disengage the tab-washers from the frame. The wheel can then be pulled down out of the fork. Do not pull on the motor cable to move the wheel.

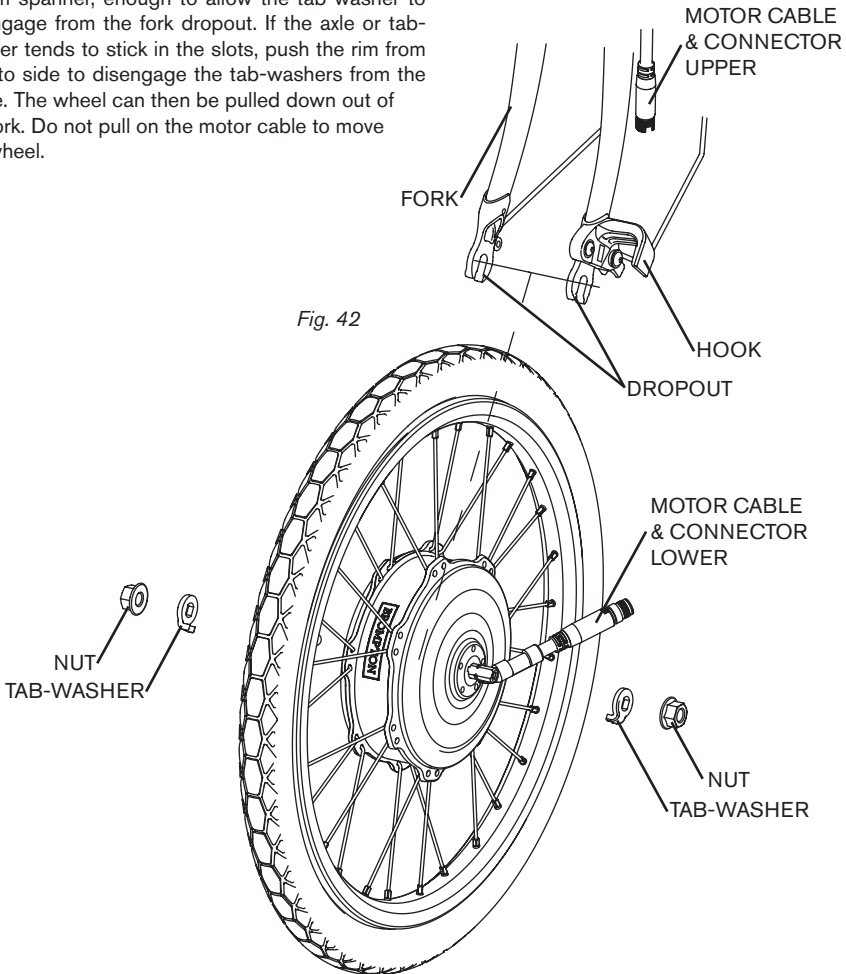

FITTING THE WHEEL

Make sure the wheel is in the correct orientation with the motor cable on the left hand side of the fork (fig. 43), next to the plastic hook.

Push the axle into the dropouts, ensuring that the washer is on the inside of the dropout and that the wheel is fully inserted on both sides. Locate the tab-washers into the dropouts and tighten both nuts to 18Nm. Check that the wheel rim is not catching on the brake blocks and the tyre does not catch the mudguard when the wheel is spun. If either of these occurs; the wheel might not be properly aligned in the fork dropouts.

CONNECTING THE CABLE

There is a white arrow on the two halves of the connector (fig. 43), align these and push the two parts together, ensuring that they go together smoothly, this should not require a great deal of force. Push the silver ring on the lower connector up and rotate it in an anticlockwise direction (viewed from the the rear with the bike upright) screw the two pieces together fully to secure the connector.

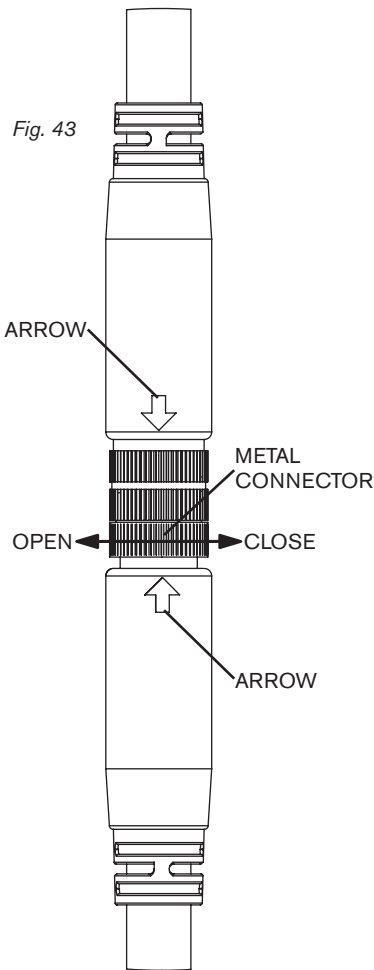

ROUTINE REPLACEMENTS

Planned replacement is advised to ensure both safety and good performance. The suggested intervals between replacements are for bicycles subjected to normal use; the most appropriate timing depends on the conditions of use and riding style. We recommend you use only genuine Brompton replacement parts for safety-critical components. Ensure you adhere to the instructions on replacement.

ALUMINIUM COMPONENTS As on other lightweight machines, aluminium alloy is used in the construction of the Brompton, and this material has a finite design life before failure. In normal use, the risk of aluminium fatigue failure is remote, even after many thousands of miles. However, the risk of failure increases with use, especially with hard riding or other severe loading. As such a failure could cause injury, the hinge clamp plates, handlebar, chain set, seat pillar and pedals should be replaced every 5,000 miles (more frequently if they are subjected to hard use), and we recommend that these items are checked regularly.

TRANSMISSION All Brompton bicycles have a self-adjusting, sprung chain tensioner to maintain correct chain tension. Over time, the chain and sprockets will wear, commonly known as chain stretch; this will result in inefficient and rough power transmission. We recommend replacing the chain and sprockets every 2,000 – 3,000 miles, but regular cleaning and lubrication will prolong the chain's life. Never use a new chain on worn sprockets or vice versa. To measure chain stretch, you may wish to use a chain stretch tool.

BRAKES Cables do not have an indefinite life, and to reduce the risk of failure, replace the cables at intervals of 4,000 miles or less. New outer-cables should be exactly the same length as the original; for best results, use genuine Brompton-specific cables and have them fitted by an authorised Brompton dealer or certified bicycle technician. Cables that are the incorrect length could affect the safety and performance of your bicycle.

GEAR CABLES These should be replaced at the same interval as brake cables. As Brompton cables are specifically designed for Brompton bikes, only genuine Brompton cables should be used. Have them fitted by an authorised Brompton dealer or certified bicycle technician. Cables that are the incorrect length could affect the safety and performance of your bicycle.

BRAKE BLOCKS When brake blocks are new they have grooves on the braking surface; once those grooves are less than 1 mm deep or no longer visible, the pads should be replaced. As brake pads are critical to the safe function of your brakes, we recommend you have them fitted by a qualified bicycle technician. Ensure you use genuine Brompton replacement brake pads, designated for use with the Brompton Electric.

TYRES The risk of punctures increases with mileage and as the tyre tread starts to wear away. Once you notice your tyre tread wearing thin, replace the tyre. This will reduce your chances of puncture and increase pedalling efficiency.

LIGHTING The electric cables used in the lighting system can wear out with the folding and unfolding of the Brompton. When the cables become worn, they should be replaced by an authorised Brompton Electric dealer. If your lights are faulty, have them inspected by a Brompton Electric Dealer, do not use the bike at night if the lights are not functioning.

BATTERY Over time the capacity of the battery will reduce, eventually the battery may need replacing. The service life of the battery will vary according with usage.

The old battery should be disposed of responsibly, in accordance with local regulations. Please contact an authorised Brompton Electric dealer, who will be able to assist you in disposal and obtaining a replacement.



SUSPENSION BLOCK AND BUSH Check the bush and suspension block for wear annually. If you notice any cracks in the suspension block, have it replaced immediately.



WHEEL RIMS The braking surfaces of the rims wear with use. As the rim reaches the point where it needs to be replaced, a line will start to appear on the braking surface.

100-MILE SERVICE We recommend having your Brompton checked by a qualified mechanic after the first 100 miles or 1-month (whichever ever comes sooner) as some items take time to bed in and may need adjusting to avoid damage.

SPOKES The tension of the spokes should be checked and adjustments made to suit. If a spoke becomes loose for any reason, neighbouring spokes will be carrying extra load and may fail.

CRANK AXLE BOLTS & PEDALS These must be checked for tightness. The correct torque is 30Nm; the thread for the LH pedal is left hand.

CABLES Although the brake and gear cables are pre-stretched, inevitably there is further initial stretch. As this affects hub-gear control, the gears should be checked for correct adjustment. It's well worth setting the brakes at the same time.

SEATPOST SLEEVE The seatpost slides up and down in a plastic sleeve inside the frame, this is a wearing part that will need replacing periodically. If the seatpost is slipping when riding or the seatpost quick release clamp nut has to be over tightened to clamp the post it could be that the sleeve is worn excessively and needs replacing. The worn sleeve can eventually cause damage to the frame itself if not replaced. Replacing the sleeve requires specialist tools and should be done by an authorised Brompton dealer.

REAR HINGE Over time the bushes in the rear frame pivot can wear, slight play will become detectable. In order to remove the play the bushes need to be replaced. This work should be undertaken by an authorised Brompton dealer, specialist tools are needed to carry out the work.

HINGE CLAMP PLATE If the plate is worn or damaged it could reduce the effectiveness of the hinge clamping and should be inspected regularly and replaced when needed. The gap between the hinge castings and the hinge clamp plate (fig. 44) when the lever is tightened, on both the handlebar hinge and the mainframe hinge should measure between 0.90mm to 3.00mm. These parts should be checked regularly and replaced when necessary.

If the gap between the hinge and hinge clamp plate is less than 0.90 mm (fig. 45) replace the hinge clamp plate. The bike should not be ridden if there is no gap between the hinge clamp plate and the hinge, until the plate is replaced.

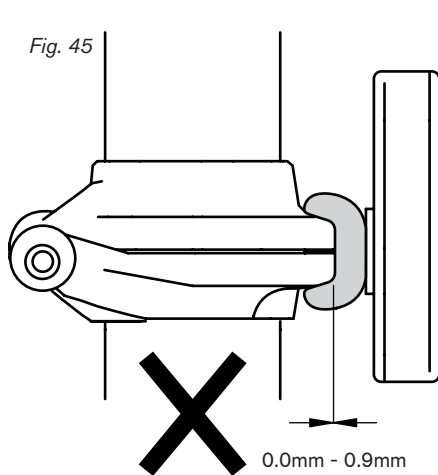
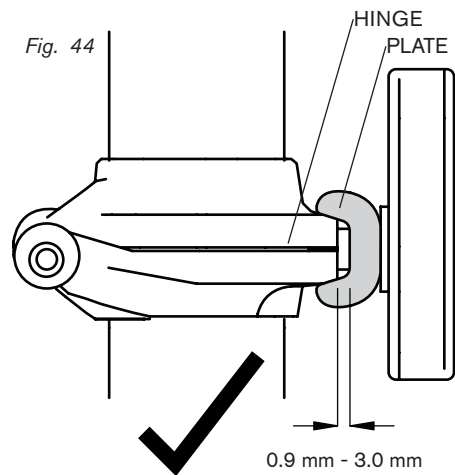

WARRANTY

If your registered bicycle has a manufacturing defect, we will replace the defective part free of charge if we are notified within seven years (in the case of the frame, two years if not registered) or two years (in the case of other parts) of the date of first purchase of the bicycle. The Brompton is for use on roads and well-made paths. It is not designed for cross-country riding: this can overstress the frame, and the tyres and wheels are unsuitable.

REGISTRATION

To activate your 7 year extended warranty you must register your bike & battery in the My Brompton section of our website to record the details and serial numbers, if your bike is stolen or we have any need to contact you, we will have a record to refer to. Your Brompton Electric dealer will assist you in completing the registration at the time of purchase, recording the date of purchase and start of the warranty period. The information remains on the Brompton database and will not be passed on to third parties <https://www.brompton.com>

SERIAL AND FRAME NUMBERS

The label at the back of the seat tube on the main frame carries the 10 digit serial number. The 6 digit frame number is stamped on the main frame just forward of the rear suspension pivot, the battery serial number is displayed on a decal on the rear of the casing. These serial numbers will be needed to be entered on registering the bike. It's also a good idea to keep a record of the numbers. Record your numbers in the blank pages at the back of this manual. If the serial number plate is removed or tampered with, the warranty is invalidated.

BROMPTON ELECTRIC WARRANTY TERMS & CONDITIONS

Thank you for choosing a Brompton Electric bicycle. Your bicycle is the product of Brompton's use of proven engineering, extensive testing, and continuous striving for superior reliability, safety, and performance. You can maintain maximum protection under these warranty terms by ensuring your Brompton Electric bicycle is serviced regularly by an authorised Brompton Electric dealer, in accordance with the recommendations in the owner's manual. Please keep records of all maintenance carried out by your Brompton Electric dealer and please ensure you make these service records available, if requested, whenever service, repair or warranty work is undertaken on your bicycle.

All new Brompton bicycles registered in the My Brompton section of our website are covered by a 7-year unlimited mileage warranty for the main frame components and a 3-year warranty on the electric components, commencing from the date of sale. The Brompton Electric Battery is covered by a 3-year or 500 charge warranty commencing from the date of sale, whichever is reached first. After 500 charge cycles the battery should have at least 65% of its original capacity. Please ensure that you keep your sales invoice in a safe place for future reference. Other non-wearing parts on your bicycle (crank arms, brake calipers, mudguards, etc.) are covered by a 2-year warranty. Brompton Electric bicycles not registered in the My Brompton section of our website are subject to a 2-year unlimited mileage warranty on the main frame and electrical components, commencing from the date of sale.

Within these warranty periods, Brompton Bicycle Ltd warrants the new Brompton Electric bicycle to be free from any defect in materials used in the manufacture, and/or workmanship at the time of its manufacture.

- Any part found to be defective during this period will be repaired or replaced by an authorised Brompton Electric Dealer or Distributor, or by the factory, at the discretion of Brompton Bicycle Ltd
- Any part replaced under the warranty terms will be covered for the remaining period of the warranty of the bike
- Any parts replaced under warranty must be returned to Brompton Bicycle Ltd by the dealer and/or distributor and will become the property of Brompton Bicycle Ltd
- Brompton may, at its discretion, make repairs or replacement of defective parts falling outside the warranty period, but such work shall not be deemed to be any admission of liability
- Brompton will bear the labour charges for work carried out under warranty
- The warranty may be transferred to subsequent owners for the balance of the remaining period.

continued on next page

Conditions and Exclusions:

1. We recommend having your Brompton Electric checked by a qualified mechanic after the first 100 miles or 1-month (whichever comes sooner) as some items take time to bed in and may need adjusting to avoid damage.
2. Routine replacements: this section of the Owner's Manual, outlines the components on the bike that will need to be replaced under routine maintenance and service of the bike. These guidelines must be followed, particularly taking into account the mileage that the bike covers, as this will affect the function of many components e.g. brake cables, chain, sprockets etc. The mileage and usage will also affect the expected life of aluminium components, which should be replaced every 5000 miles of use (or sooner if particularly hard/heavy use) and do not, therefore, come within the warranty terms for the bike, detailed above.
3. The warranty described above is only valid within the country in which the bicycle was purchased.
4. Bikes exported from one country to another will be supported, within the warranty period, by the free issue of parts from the factory, where necessary. However, the Brompton Electric distributor or dealer in the new country will normally charge for the labour required to undertake warranty repairs, and for any import duty levied on the free-issued parts.
5. The bike must not have been used for unauthorised competition, misused*, inadequately maintained, or incorrectly serviced or maintained.
6. The bike must not have been subject to any modification, repair or replacement other than as authorised by Brompton Bicycle Ltd.
7. The bike must have been serviced by an authorised Brompton Electric Dealer.
8. Defects caused by faulty adjustment, or repairs and alterations performed by a non-authorised Brompton Electric Dealer, are not covered by this warranty.
9. Defects caused by the use of parts and accessories not authorised by Brompton Bicycle Ltd are not covered by this warranty.
10. The warranty does not cover the cost of removal and replacement of parts and accessories, unless supplied as original equipment, or recommended by Brompton Bicycle Ltd.
11. Components which are expected to wear as part of their normal function, such as tyres, bulbs, chains, sprockets, brake pads, bearings etc. are excluded from the terms of this warranty, unless there is a manufacturing defect in the part.
12. Other items excluded from warranty are the saddle, luggage, paint, chrome, polished aluminium items, or decal where deterioration has been caused by normal wear and tear, exposure or lack of correct maintenance.
13. The warranty does not cover frame parts or bicycles that have been repainted and/or had the original paintwork removed.
14. Any additional battery, other than the Brompton electric battery, supplied with the bicycle is excluded from warranty, save for any leak that is present at the time of delivery.
15. The battery warranty excludes any issues resulting from; damage to the casing and connectors caused by misuse, improper use, connection or maintenance, damage due to the use of non approved chargers, deep discharged batteries due to inappropriate storage conditions.
16. The warranty does not cover bikes used on a commercial basis, e.g. by couriers or despatch riders, etc.
17. The warranty does not cover defects which have not been reported to an authorised dealer within ten days of discovery of the defect.
18. Your bicycle will require more frequent servicing if operated in severe climates or conditions, such as a marine environment or heavily salt-treated roads; in deep snow (above half axle height); in very dusty/sandy terrain; in strong sunlight/high levels of UV radiation. Such environments will potentially cause premature failure of finishes to the frame and components, and such deterioration is excluded from these warranty terms. Brompton Bicycle Ltd has taken great care in the selection of materials, plating and painting techniques so as to provide its customers with a quality cosmetic appearance allied to durability. However, where your bicycle is often used in hostile environmental conditions such as those indicated, it is essential that the bicycle is washed, dried and that lost lubrication is replaced to ensure your bike remains in the best condition. Your dealer can provide further information and advice if required. Ultimately, the appearance of your bicycle will very much depend on the care it receives.
19. Should a warranty claim become necessary, Brompton Bicycle Ltd and its Distributors or Dealers shall not be liable for the cost of transportation of the bicycle to or from the authorised Brompton Electric Dealer, or for expenses incurred while the bicycle is off the road, including costs associated with loss of use, inconvenience, lost time, commercial losses or other incidental or consequential damages.

This warranty shall be interpreted in accordance with English law and any question arising from this warranty shall be subject to the jurisdiction of the English courts. Any statement, condition, representation, description or warranty otherwise contained in any catalogue, advertisement or other publication shall not be construed as enlarging, varying or overriding anything contained herein.

Brompton Bicycle Ltd reserves the right to make alterations or improvements, without notification, to any model or machine, without obligation to do so to bicycles already sold. This warranty does not affect your statutory rights.

* Misuse includes any use not in accordance with the recommendations made in the owner's manual, and any use contrary to the warnings given in that same handbook. In addition, misuse will include, but not be limited to, any use of the bicycle which does not constitute normal road use, as your Brompton Electric is intended for use on roads and well-made paths. It is not designed for cross country riding, which can overstress the frame and for which the tyres and wheels are unsuitable.

BROMPTON BICYCLE LTD
Unit 1 Greenford Park
Ockham Drive
Greenford
Middlesex
UB6 0FD
© Brompton Bicycle Ltd 2021

EN15194:2017

CPSC 16 CFR 1512